

## AM-1W

### REAL-TIME STEERING ARRAY MICROPHONE



The AM-1W is a high sound quality microphone system that features automatic adjustment capability in a slim configuration. Composed of an array microphone connected to a separate control unit, it is ideal for installations and use on lecterns. The array microphone unit's eight internal microphones detect and track the location of the sound source, picking up audio clearly and without interruption, allowing speakers to conduct presentations more naturally without worrying about the location of the microphone. In addition, setup of operation can be performed using a PC browser. The control unit can be mounted in an EIA Standard rack with the use of optional rack-mounting brackets. (1-unit size)

### Key features

- Built-in voice detection sensor captures voice from up to 3 m and to tracking range angles up to 180°
- Level compensation for reduced volume variations
- Narrow (50°) directivity assuring minimal acoustic feedback
- Innovative pad-like form permitting unobtrusive placement
- Removal of barrier between speaker and audience
- Freedom to adopt a comfortable speaking posture
- Ability to move and gesture naturally
- Adjustment by PC is also possible
- Tracking distance/range, sensitivity/speed, Mute on/off

## Specifications

System Components	Array microphone x 1, Control unit x 1
Array Microphone	
Power Source	24 V DC (supplied from the Control unit)
Microphone	Unidirectional electret condenser microphone
Directivity Angle	Horizontal: 50° (800 Hz - 18 kHz, Array mode), 180° (Cardioid mode), Vertical: 90°
Frequency Response	150 Hz - 18 kHz
Maximum Sound Pressure Level	100 dB SPL
User Control	Mute switch
Indicator	Microphone status indicator (output: green, mute: red)
Microphone Cable	Shielded twisted pair cable 10 m (32.81 ft) with connector equivalent to TA-3
Maximum Cable Length	70 m (229.66 ft) (use of the AES/EBU cable)
Finish	Body, Punched net: Surface-treated steel plate, white (RAL 9016 equivalent), 30% gloss Side cover: ABS resin, white (RAL 9016 equivalent)
Dimensions	483.9 (W) x 22.1 (H) x 64.9 (D) mm (19.05" x 0.87" x 2.56") (excluding Cable)
Weight	1.2 kg (2.65 lb)
Control Unit	
Power Source	24 V DC (supplied from the AC adapter (option)) Usable DC power supply plug: 5.5 mm (0.22") outer diameter, 2.1 mm (0.08") inner diameter, 9.5 mm (0.37") long, and non-polarity type.
Current Consumption	410 mA or less
Signal to Noise Ratio	90 dB or more
Input	Combined type of TA-3 (dedicated to the array microphone)
Output	Combined type of XLR-3-32, Removable terminal block (3 pins)
Network	Network I/F: 10BASE-T/100BASE-TX, RJ45 connector Network protocol: TCP/IP, HTTP
Level Control	Output level selection (+4 dB (*1), -10 dB (*2), -50 dB (*1)) LOW CUT ON/OFF"
User Control	Power switch
Indicators	Power indicator (blue), Mute indicator (red), Signal indicator (green)
Finish	Pre-coated steel plate, black, 30 % gloss
Dimensions	210 (W) x 45.7 (H) x 271.5 (D) mm (8.27" x 1.8" x 10.69")
Weight	1.5 kg (3.31 lb)
Dedicated Software	PC browser software (for setting of tracking distance/range, sensitivity/speed, mute ON/OFF)
Operating Temperature	0 °C to +40 °C (32 °F to 104 °F)
Operating Humidity	90 %RH (no condensation)
Included Accessories	Removable terminal plug (3 pins) x1

## Optional Accessories

AC adapter: AD-246

Rack mounting bracket: MB-15B-BK (for rack mounting one control unit), MB-15B-J (for rack mounting two control units), Wall mounting bracket: YC-850 (for one control unit)

(\*1) 0 dB = 0.775 V

(\*2) 0 dB = 1 V

## PC requirements

## PC Requirements

OS	Windows 10 Pro (64 bits) (This is the verified operation system.)
Web Browser	Google Chrome (Version 56.0.2924,87) (This is the verified web browser programs and versions.)

## Dimensions

### Array Microphone

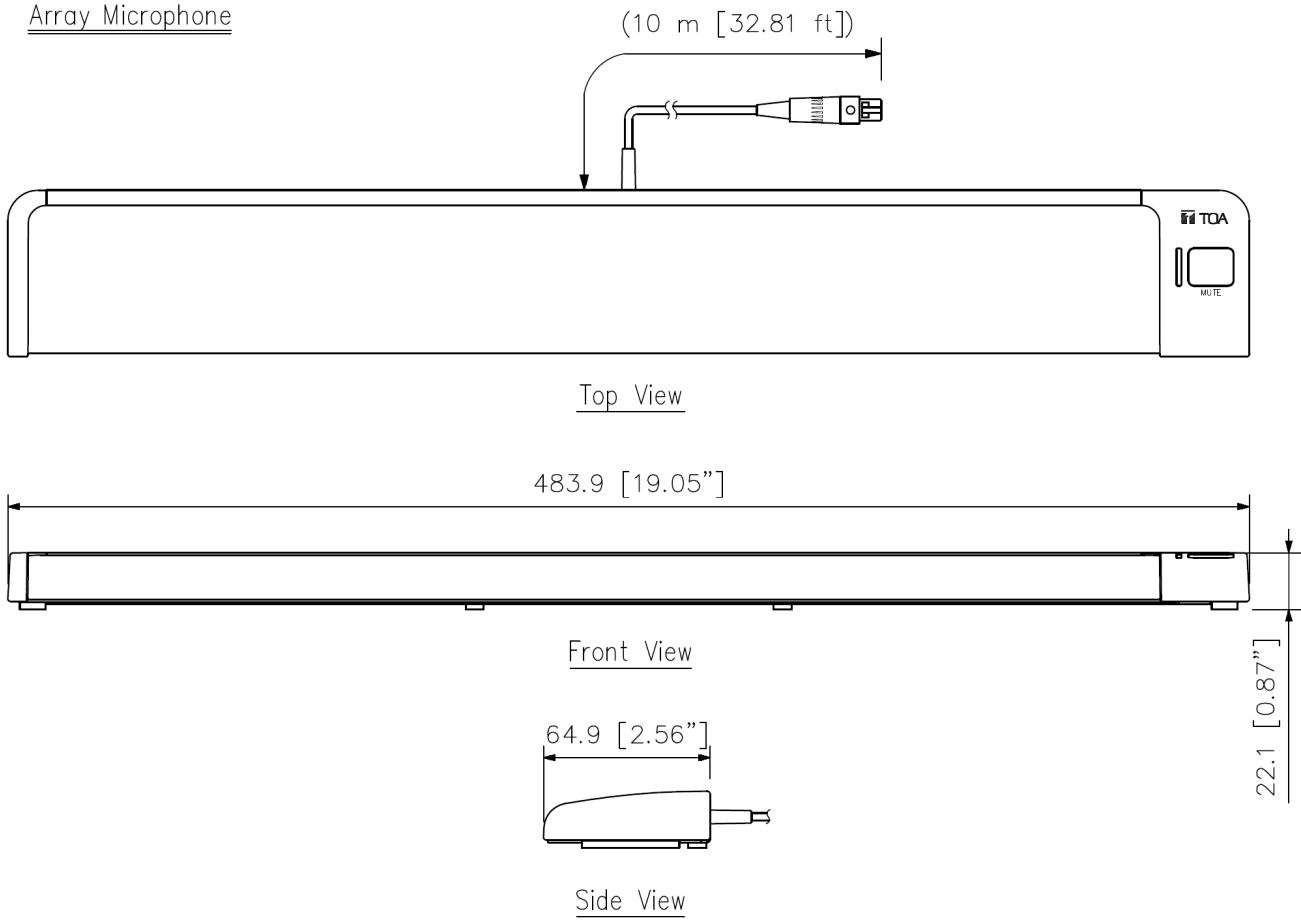

### Control Unit

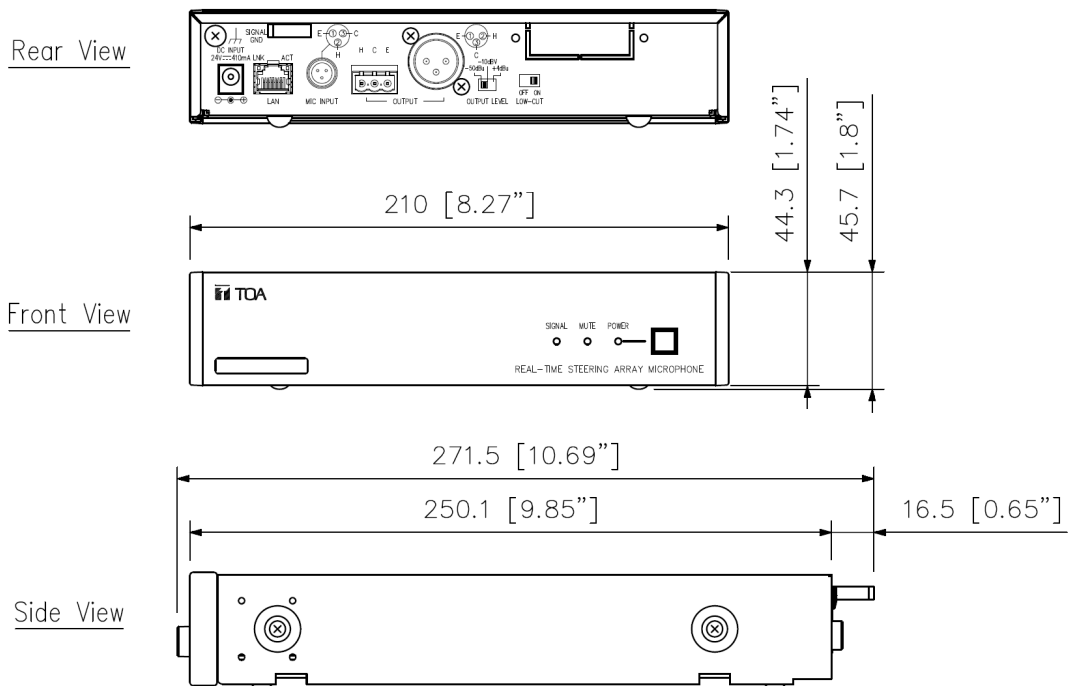

## A&E specifications

The system shall consist of a microphone and a control unit. The microphone shall incorporate eight unidirectional condenser elements arranged in a linear array and enclosed in a metal housing of 482 mm long by 65 mm deep and 20 mm high. The microphone case shall house Digital Signal Processing which controls the microphone's sound source sensing and directional characteristics. The microphone array shall provide a pickup pattern of approximately 50° Horizontal by 90° Vertical (from boundary surface to above the mic). The array shall detect any sound source in a programmed area of acceptance and steer the pattern immediately towards that source based on first arrival of signal. The acceptance angle may be adjusted between 180° and any angle down to 30° within the 180° arc. The microphone shall feature a MUTE on/off button with an LED indicator which shall turn between Green and Red depending on the microphone's mute status. The microphone shall incorporate a 10 meter shielded twisted-pair cable terminated in a mini-XLR female connector. The microphone shall be available in either a black or white finish. The microphone may be placed on a lectern or table and is equipped with rubber isolation pads to reduce transmission of vibration from the mounting surface. The control unit shall be housed in a metal case measuring 210 mm Wide x 44 mm High x 250 mm Depth. It shall incorporate additional signal processing for the microphone, including Digital to Analog conversion and a pre-amplifier. The input to the control unit shall be a balanced male mini-XLR. The cable distance between the microphone and control unit shall not be more than 70 m using AES/EBU digital audio cable. A signal present indicator shall light when the audio signal is being output. Electronically balanced analog audio is output via a male XLR connector and a removable terminal block with 3 pins in parallel. The analog output shall be capable of providing a +4 dB professional level, -10 dB consumer level and -50 dB microphone level, selectable by a switch on the control unit. A Low-cut on/off switch on the rear panel shall be used to reduce the low frequency response. An RJ-45 connector shall provide the connection from the controller to a PC or wireless Ethernet gateway. The control unit shall have a power on/off switch with an LED indicator, as well as an LED MUTE status indicator. The system shall be powered by an optional power supply (TOA model AD-246). System parameters shall be accessible from any PC or device using an onboard web browser interface. System parameters shall include, but not be limited to, width and depth of the area of acceptance, distance compensation, level, mute on/off, mute disable, and three presets. Manufacturer: TOA Corporation Model: AM-1B(Black) or AM-1W(White)