

St. Josaphat Cathedral,- Edmonton, Canada

St. Josaphat Cathedral is a Ukrainian Catholic cathedral in Edmonton. It is one of the best examples of Byzantine Rite church architecture in Canada. TOA successfully designed and delivered a professional sound system to improve intelligibility.



SR-H2/SR-S4S

St Paul's Lutheran Church - Edmonton, Canada

TOA has successfully designed a sound system to this community focused church. TOA's HX-5 compact line array speakers mounted on the ceiling delivered the sound quality deserved for such a close knit congregation.



HX-5 Line Array's

Hope Lutheran Church - Toronto, Canada

Hope Lutheran Church is a vibrant, growing church located on the eastern side of Toronto. TOA has installed Digital Amplifiers, HX-5 compact line arrays and wide dispersion ceiling speakers for the church.



HX-5/FB-120/DA-250F/F-122C

Gurudwara Sikh Temple - Brampton Canada

The Temple's main space is a large 60' x 130' room. TOA's designed team focused on minimizing reverberation which was a challenge. The project required the HX-7 and Sub woofers to be hung from the ceiling and adjusted to cover the entire room.



HX-7/FB-120



Solutions for House of Worship





Why should a House of Worship have a sound system?

Because scripture lessons and sermons delivered by a pastor need to reach the congregation clearly. And because musical performances by choruses and bands are an integral part of religious activities.

TOA sound systems for Houses of Worship offer numerous benefits:

- They deliver high-quality sound that is both powerful and intelligible.
- Users can create sound environments that match a particular purpose. TOA's unique digital processing technology can work to minimize reverberation during speeches or make full use of it during musical performances.
- Easily adjustable acoustic settings provide the flexibility to match various usage applications.

For 85 years, TOA has espoused the belief that "we supply sound, not equipment." With this in mind, we work to create sound environments suitable for sacred places of worship. A place of worship requires a sound system that enables the audio environment to be appropriately controlled—in other words, a system that can produce the optimal sound when required without emitting any unwanted sound.

This brochure introduces a selection of our currently available sound systems. These systems can be configured in a countless variety of ways to match the type of architecture, the application, and the desired acoustic quality at the installation location.

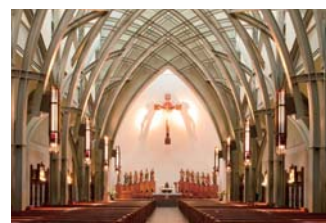

Featured Products

AM-1 Real-time Steering Array Microphone

The presenter would no longer need to be "microphone-conscious" to get a uniform sound level while speaking and moving.

The AM-1 has achieved the unique function of detecting the sound source location and steering its angle automatically in real-time to capture the targeted sound more efficiently. In addition, the special, user-friendly app and firmware allow the user to monitor the status of the sound source tracking and make changes to its setting parameters with an iPad™ or a PC.



iPad™ APP



AM-1C Control Unit



SR-D8 Active Line Array

DSP beam steering with instant simulation and high-speed communication

As well as processing both analog and digital audio input, this innovative speaker harnesses 8 built-in digital amplifiers to project sound waves to targeted areas with greater precision than is possible with conventional speakers. By digitally shaping the width and angle of acoustic beams, it can steer sound precisely to desired areas without requiring a change of installation location.

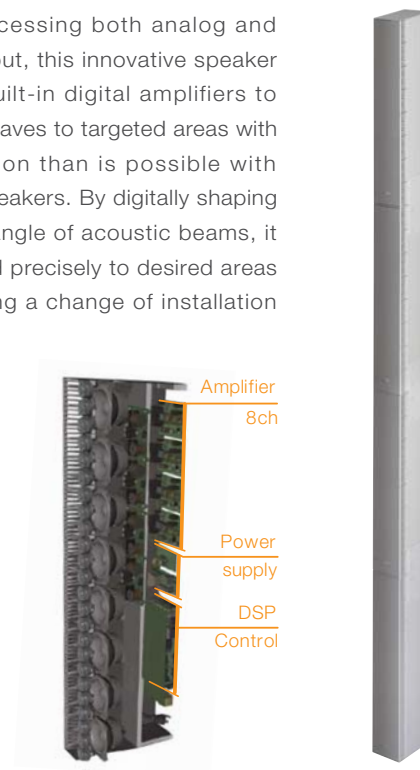

Amplifier 8ch
Power supply
DSP Control

Beam width: 0°/Beam angle: 0°

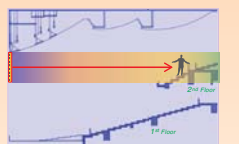
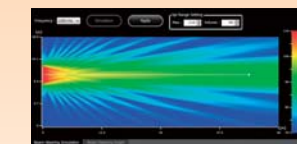

Beam split in two directions

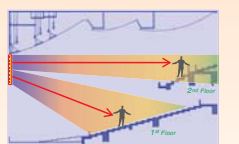
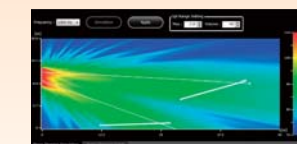

Beam splitting point: At the center point of all the transducers in a single stack.

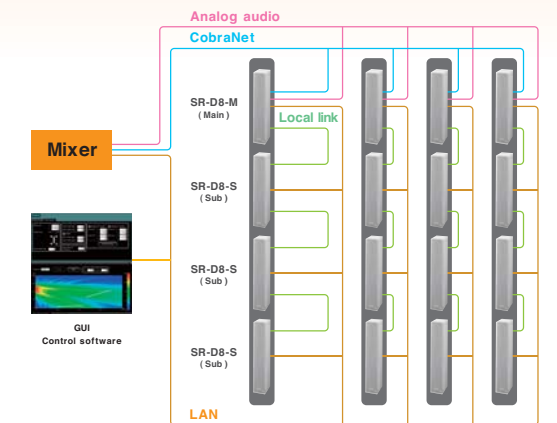

H-1 Interior Design Speaker

Sleek, stylish appearance with paintable grille blends well with architecture.

Minimum reflection design reduces sound wave reflections typical of conventional bracket-mounted "box" type speakers. Loudspeaker components rotate internally to allow flexible aiming. Multiple H-1 speakers installed behind the pews help to ensure that voices are clearly intelligible.

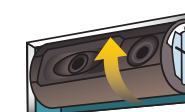

Up to 90 locking driver positioning adjustment.

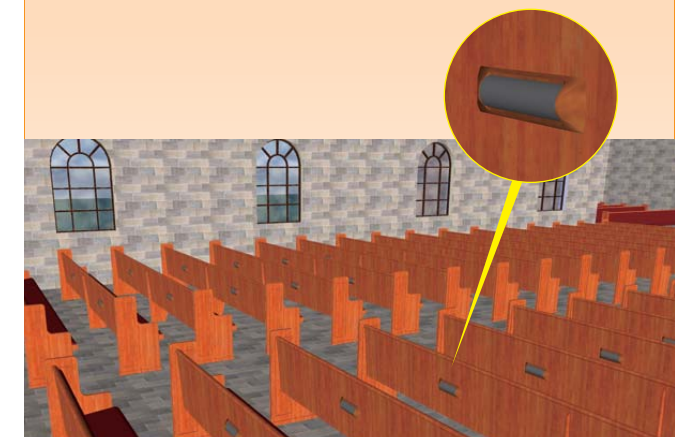

Applications Examples



Basic Speech Applications

This is a simple, low-cost system comprising only the absolute essentials: a microphone, a mixer/ amplifier, and an F-Box wide-dispersion speaker. It's ideal for compact venues with a small amount of reverberation and with a capacity of 100 to 200 people. Thanks to their compact size and wide angle of coverage, the F-Box series speakers can cover a targeted area with a minimum number of units.

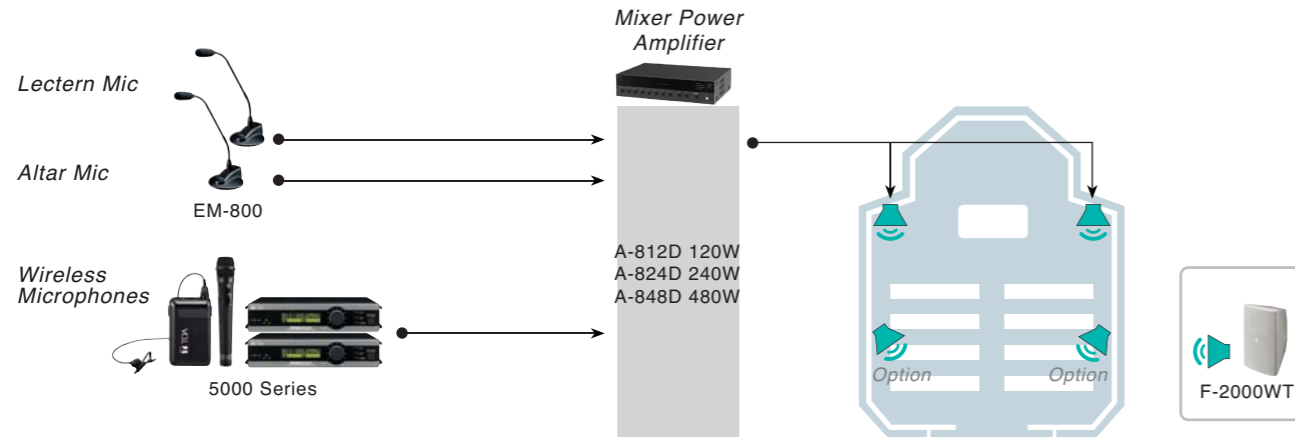

Standard Speech Applications

The system shown here is ideal for venues with a capacity of 400 to 500 people. At the touch of a button, the M-633D digital stereo mixer can engage its ARC (Automatic Resonance Control) function to create a sound environment with minimum reverberation. At the same time, the DP-SP3 Digital Speaker Processor takes care of speaker equalization and delay functions. Slim and stylish Type H line array speakers deliver clear sound without detracting from the architectural aesthetics of the place of worship.

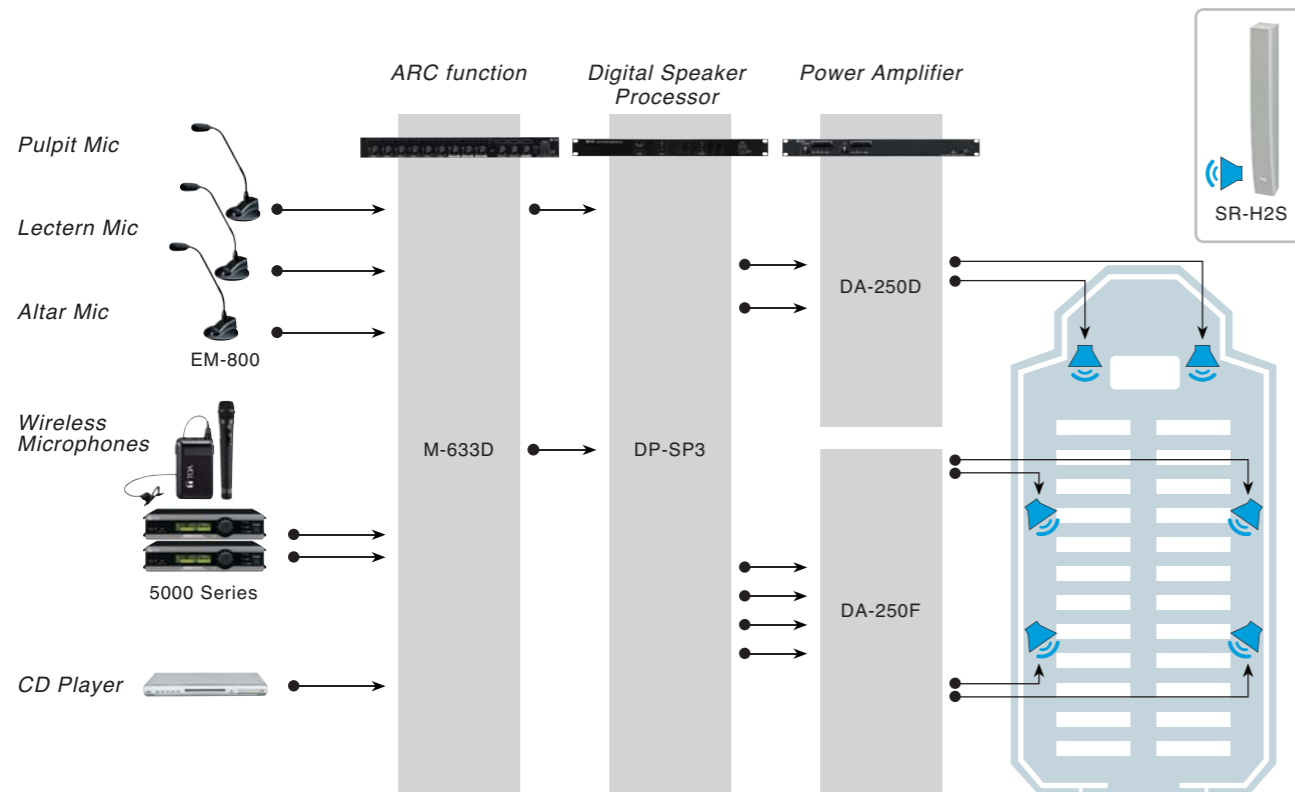

Speech/Music Reinforcement Applications

Designed specifically for use in places of worship, this system supports both speech and music applications. At the touch of a button, the M-864D digital stereo mixer can engage its ARC (Automatic Resonance Control) function to create a sound environment with minimum reverberation. Using the remote control, you can easily call up preset settings made specifically for different types of event.

The DP-SP3 digital speaker processor brings the best out of TOA speakers while also adding a delay effect to the rear speakers. The HX-7 variable dispersion speaker and FB-150 subwoofer provide a boost of power and intelligibility both to musical performances and to regular sermons. Meanwhile, the F-1000 wide-dispersion speaker installed in the pulpit serves as a monitor speaker.

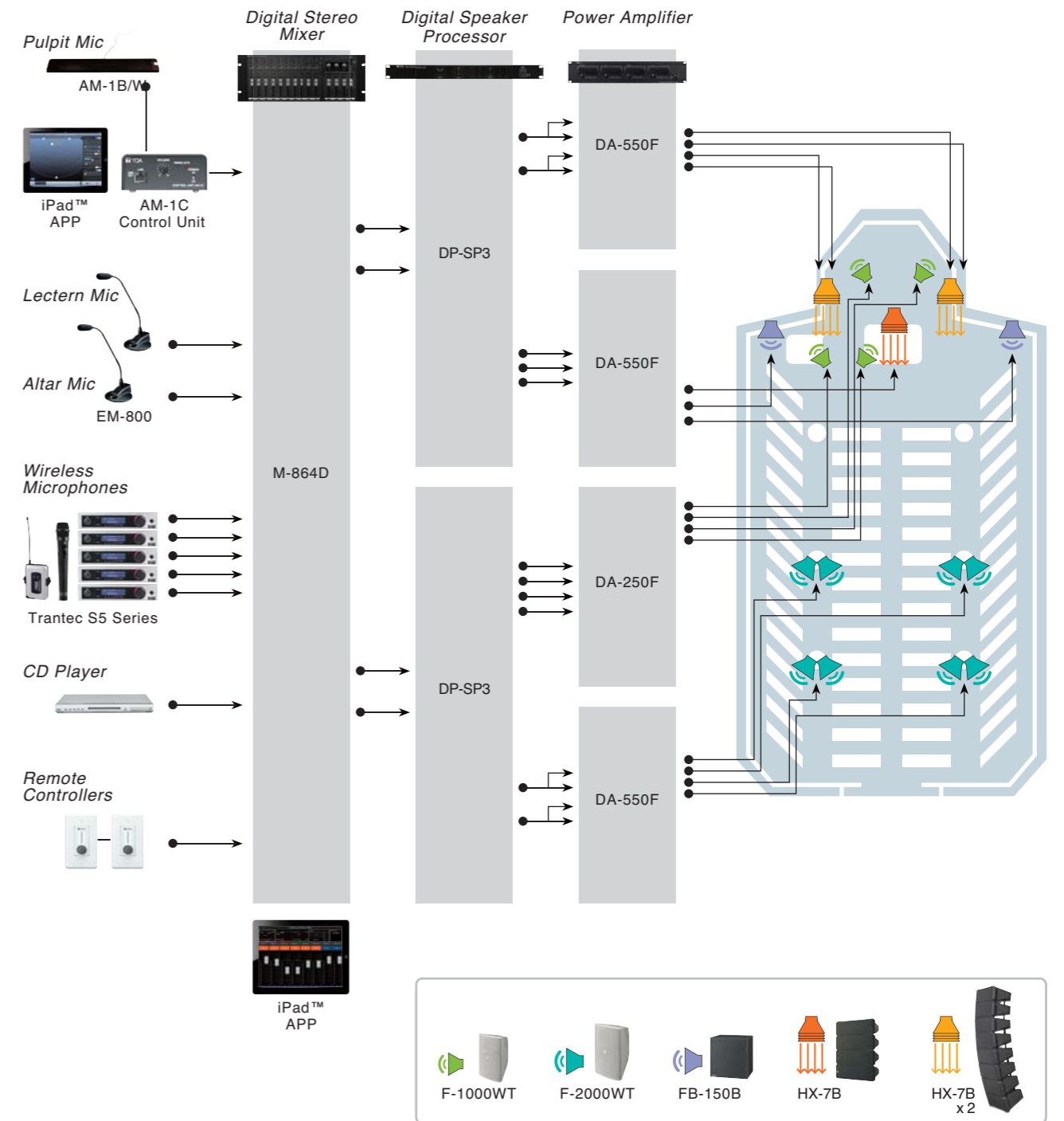

SYNC-Drive™ SYnchronous Nexus Control

Sync-Drive is a wavefront control technology that keeps sound waves in phase with their sources at the speakers to create an ideal linear sound source. TOA's line array speakers incorporate this technology.

Sync-Drive™ Synchronous Nexus Control Drive Technology

- Type H: Front grille delivers wide directionality for high frequencies, even without tweeters.
- Type S: Two-way unit array and SR-S4S clothoid curve configuration.
- HX-5: Variable directionality via variable arc array of the two-way module.
- HX-7: Wavefront control throat and variable directionality via two-way module's variable arc array.
- SR-D8: Variable directionality via signal processing based on the SR-S4.

Line Array Type H

Slim enclosure for clearly intelligible speech

Designed to minimize reflection and feedback, while supporting uniformly dispersed sound and intelligible speech. Suitable for environments prone to reverberation. Slim, 84 mm (3.3")-wide enclosures with high-quality 70 mm (2.8") full-range speaker units.



SR-H2/H3

Line Array Type S

Increased power and low-frequency response compared to Type H

Designed to minimize reflection and feedback, while supporting uniformly dispersed sound and intelligible speech. Suitable for environments prone to reverberation. Multiple drivers (8 LF, 24 HF) for high sensitivity and power handling. Supports bi-amp or single-amp drive.



SR-S4S/SR-S4L

Tilt = -3° Dispersion image

Mechanically Steerable Line Array Speaker

Original built-in steering mechanism ensures optimal sound coverage

The addition of a low-frequency expander extends the frequency range, adding depth to sound reproduction for both speech and music. Tilt and dispersion angle are manually adjustable. Can be mounted flush with walls.

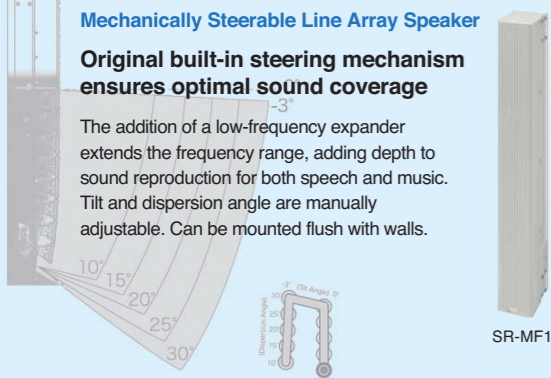

SR-MF1

Active Line Array

DSP beam steering with instant simulation and high-speed communication

Eight built-in digital amplifiers project sound waves to targeted areas. DSP functionality includes gain, mute, compression, delay, auto-mixing, high/low pass filters, high/low shelving filters, and a notch filter. Equipped with two analog audio input terminals and four CobraNet-compatible digital audio input terminals.



SR-D8S/SR-D8M

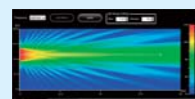

HX-5 Series

Low-cost solution for boosting speech and music

Compact modular design includes four preassembled modules with four LF drivers and twelve HF dome tweeters. Dispersion angle adjustable to 60, 45, 30, and 15 degrees. Designed for small- to medium-sized places of worship.



HX-7 Series

Powerful variable dispersion speaker — "From a Whisper to a Scream"

Excellent sound quality for both speech and music applications. Modular speaker design includes four preassembled modules with two LF speakers and a waveguide loaded HF compression driver. Dispersion angle adjustable to 45, 30, 15, and 0 degrees (and 60 degrees with optional brackets). Suitable for medium-sized places of worship.



F-Box Speaker

Compact enclosure and wide coverage

Two-way bass-reflex design. Wide-dispersion characteristics for better sound coverage and improved tonal response. Included accessory brackets expand options for installation.



FB-120 Subwoofer

Compact 12" subwoofer

Designed for use in conjunction with TOA HX-5 series or other full-range speakers. Ideal for reproducing dynamic low-frequency sound for religious music applications. Wide frequency range. 600W continuous program. Sensitivity (1W, 1m): 90 dB.



FB-150 Subwoofer

15" subwoofer

Designed for use in conjunction with TOA HX-7 series or other full-range speakers. Ideal for reproducing dynamic low-frequency sound for religious music applications. 600W continuous program. Sensitivity (1W, 1m): 93 dB.



DP-SP3 Digital Speaker Processor

Built-in library of presets for TOA speakers

24-bit, 96 kHz sampling for clear, high-quality, realistic sound, with a full sense of presence. Two inputs and six outputs; processor can work with a three-way multi-amp system. Includes intuitive control software. Full array of essential audio processing tools: compressor, parametric EQ, output delay, and mute.

Automatic Resonance Control (ARC)

An advanced measurement and processing algorithm that improves speech intelligibility and sound quality in facilities with challenging acoustic environments. Automatically identifies room mode frequencies and applies an inverse response curve to compensate for the measured room response.

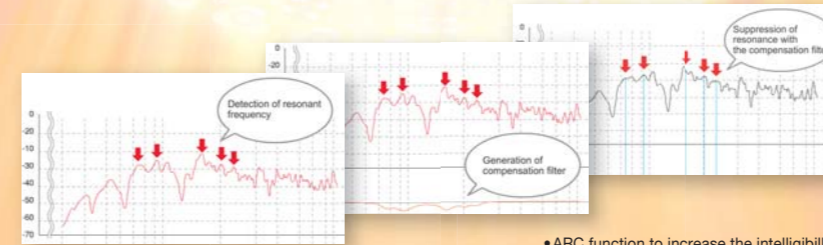

•ARC function to increase the intelligibility

M-633D ARC FBS

Acoustic perfection at a touch

Inputs: 6 mono and 3 stereo. Outputs: 2 mono, 1 stereo, and 1 stereo rec. ARC eliminates resonance at the touch of a button, while Feedback Suppressor (FBS) automatically prevents feedback.



M-864D ARC FBS

Fader-type digital stereo mixer with ARC

Optimal sound control features: ARC, FBS, and auto mute (ducker). Preset memory enables operators to store user-specified settings to suit specific needs. Optional remote control panels permit convenient remote operation, including preset memory recall.



iPad™ APP

M-9000M2

Modular matrix mixer with dual-channel DSP function

Expandable to 8-in by 8-out construction with optional modules. Includes EQ, delay, VOX switch, and compressor functions. Can store up to 32 patterns of setup parameters and event presets. A variety of remote control panels help to ensure smoothly run religious services.



Remote Control Panels

Designed for use in conjunction with M-9000M2 and M-864D.



ZM-9011 ZM-9012 ZM-9013 ZM-9014

MA-725F AM

2 mic inputs and 4 independent line inputs 4 aux inputs. 1 rec out, and 4 speaker output zones. Remote volume and power controls.



A-800 Series

6 mic inputs (ON or OFF switchable for each INPUT 1-4, 2 input 900 modules, 1 rec out, pre-amp. Simple operation and durable construction.



DA Series Multi-Channel Digital Power Amplifiers

Light and compact body. Independent power supply for each channel ensures high efficiency and reliability.



DA-250D/DH
DA-250F/FH
DA-550F/500FH



AM-1B Real-time Steering Array Microphone System

Innovative low-profile array microphone for places of worship

Equipped with an 8-condenser capsule, the AM-1B detects the location of the sound source and automatically steers its beam angle to focus on that source. Presenter no longer needs to be "microphone-conscious" to get a uniform sound level while speaking and moving.

EM-800/ST-800 Gooseneck Microphone/Stand

Desk-top condenser microphone with unidirectional pattern

Excellent high-frequency response for clear audio output. Rejects undesirable off-axis noise to minimize potential for feedback. Ideal for speech-related applications.



EM-700 Boundary Microphone

Unobtrusive, low-profile design

Employs an electret condenser element with unidirectional pattern and low-cut switch. Ideal for recording and speech-related applications.



Lavalier Microphone

Variety of mic's to meet industry requirements



TOA 5000 Series Wireless Microphone System

Offering outstanding intelligibility

Up to 16 simultaneous channels. Receiver and transmitter can be combined freely.



Trantec Wireless Microphone System

Ideal for vocalists and musicians

Up to 24 simultaneous channels. Combines with a wide variety of accessories to meet professional needs. Supports USB-based computer control and monitoring (S5.5 series). Supports USB-based computer control and monitoring (S5.5 series).

