



## OPERATING INSTRUCTIONS

**LINE ARRAY SPEAKERS**

**SR-S4L**

**SR-S4S**

**EXTENSION PLATE (optional)**

**SR-EP4**

**PROTECTION PAD (optional)**

**SR-PP4**

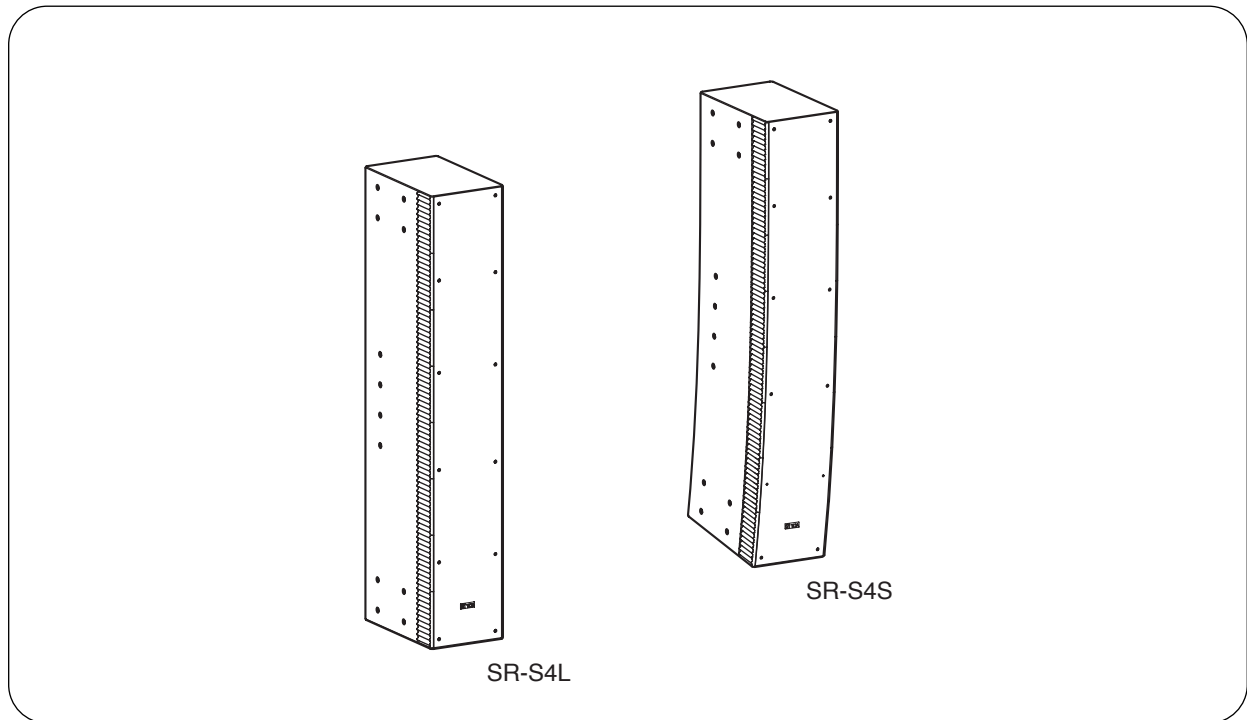

Thank you for purchasing TOA's Line Array Speakers and their associated products.  
Please carefully follow the instructions in this manual to ensure long, trouble-free use of your equipment.

# TABLE OF CONTENTS

<b>1. SAFETY PRECAUTIONS</b> .....	3
<b>2. GENERAL DESCRIPTION</b> .....	5
<b>3. FEATURES</b> .....	5
<b>4. COVERAGE AREA</b> .....	6
<b>5. DIMENSIONAL DIAGRAM</b>	
5.1. Line Array Speaker SR-S4L .....	7
5.2. Line Array Speaker SR-S4S .....	7
<b>6. SINGLE-AMPLIFIER DRIVE AND BI-AMPLIFIER DRIVE</b> .....	8
<b>7. INTERNAL WIRING DIAGRAM</b> .....	8
<b>8. CHANGING TO HIGH IMPEDANCE</b> .....	9
<b>9. JOINING SPEAKERS</b> .....	10
<b>10. ATTACHING THE PROTECTION PAD TO THE SPEAKER EDGE</b> .....	11
<b>11. CHANGING SINGLE-AMPLIFIER DRIVE TO BI-AMPLIFIER DRIVE SYSTEM</b> .....	12
<b>12. INTERNAL WIRING DIAGRAM FOR THE BI-AMPLIFIER DRIVE SYSTEM</b> .....	13
<b>13. DIGITAL PROCESSOR FILTERING</b>	
13.1. Single-Amplifier Drive (Factory-Setting) .....	14
13.2. Bi-Amplifier Drive .....	14
<b>14. SPECIFICATIONS</b>	
14.1. Line Array Speaker SR-S4L, SR-S4S .....	15
14.2. Extension Plate SR-EP4 (optional) .....	16
14.3. Protection Pad SR-PP4 (optional) .....	16

# 1. SAFETY PRECAUTIONS

- Before installation or use, be sure to carefully read all the instructions in this section for correct and safe operation.
- Be sure to follow all the precautionary instructions in this section, which contain important warnings and/or cautions regarding safety.
- After reading, keep this manual handy for future reference.

## Safety Symbol and Message Conventions

Safety symbols and messages described below are used in this manual to prevent bodily injury and property damage which could result from mishandling. Before operating your product, read this manual first and understand the safety symbols and messages so you are thoroughly aware of the potential safety hazards.



## **WARNING**

Indicates a potentially hazardous situation which, if mishandled, could result in death or serious personal injury.

### When Installing the Unit

- Avoid installing or mounting the unit in unstable locations, such as on a rickety table or a slanted surface. Doing so may result in the unit falling down and causing personal injury and/or property damage.
- Refer all installation work to the dealer from whom the speaker was purchased. Installation requires extensive technical knowledge and experience. The speaker may fall off if incorrectly installed, resulting in possible personal injury.
- Flying Precautions  
Be sure to follow the instructions below. Otherwise, the suspension wires or belts may be off or snap and the speaker may fall off, causing personal injury.
  - Check to confirm that the suspension wires and belts are strong enough to withstand the speaker load.
  - The connectors of the suspension wires and belts must be securely linked with those of the speaker.
  - All parts and components (such as enclosures, metal pieces, and screws) must be free from any deformation, crack, and corrosion.
  - Be sure to use screws supplied with the optional flying hardware when installing the speaker using such hardware.
- Install the unit only in a location that can structurally support the weight of the unit and the mounting bracket. Doing otherwise may result in the unit falling down and causing personal injury and/or property damage.
- Owing to the unit's size and weight, be sure that at least two persons are available to install the unit. Failure to do so could result in personal injury.
- Do not use other methods than specified to install the speaker. Extreme force is applied to the unit and the unit could fall off, possibly resulting in personal injuries.
- Use nuts and bolts that are appropriate for the ceiling's or wall's structure and composition. Failure to do so may cause the speaker to fall, resulting in material damage and possible personal injury.
- Tighten each nut and bolt securely. Ensure that the bracket has no loose joints after installation to prevent accidents that could result in personal injury.
- Use the specified mounting bracket in combination. Doing otherwise may cause the unit or component to fall off, resulting in personal injury.
- Do not mount the unit in locations exposed to constant vibration. The mounting bracket can be damaged by excessive vibration, potentially causing the unit to fall, which could result in personal injury.



## **CAUTION**

Indicates a potentially hazardous situation which, if mishandled, could result in moderate or minor personal injury, and/or property damage.

### **When Installing the Unit**

- Avoid placing the unit in a doorway or other high traffic area as people may trip on the equipment and cords, or be injured by falling objects.
- Avoid touching the unit's sharp metal edge to prevent injury.
- When installing the speaker at head height, attach the optional SR-PP4 Protection Pad to the bottom of the speaker. Failure to do so may cause injury if people hit their heads directly against the speaker.

### **When the Unit is in Use**

- Do not operate the unit for an extended period of time with the sound distorting. This is an indication of a malfunction, which in turn can cause heat to generate and result in a fire.
- Do not stand or sit on, nor hang down from the unit as this may cause it to fall down or drop, resulting in personal injury and/or property damage.
- Have the unit checked periodically by the shop from where it was purchased. Failure to do so may result in corrosion or damage to the unit or its mounting bracket that could cause the unit to fall, possibly causing personal injury.

## 2. GENERAL DESCRIPTION

Featuring slim construction, the SR-S4 series are 2-way line array speakers containing 32 speaker elements. The sound source speaker elements are vertically arranged in close proximity to each other, and form a continuous linear sound source, achieving uniform sound pressure with less attenuation due to distance.

The SR-S4L speaker is of a linear design which is ideal for long distance sound transmission applications, while the SR-S4S features a curved line having a 10° vertical coverage area, and is designed to cover relatively short distance applications.

It is also possible to combine both the linear and curved line types to configure an array that continuously covers applications ranging from short to long distances.

## 3. FEATURES

- The SR-S4 series is a 2-way line array speaker having eight 10 cm woofers for low-frequency output, and 24 small tweeters for high-frequency sound output. Both the woofers and tweeters are arranged in the front and rear on the same axis, providing a symmetrical, uniform coverage area.
- Since the linear sound source effect prevents energy from attenuating even at longer distances, the line array speaker compares favorably with normal types of speakers in its ability to project sound long distances. This realizes less difference in sound volume between areas close and far from the speaker, for a more uniform sound field.
- Since the speaker's vertical sound dispersion is suppressed, sound is only directed at the target area. The speaker's construction is not influenced by sound reflection from ceiling or floor surfaces, and can provide clear sounds even in spaces affected by long reverberation times or other poor acoustic conditions.
- Since the attenuation of sound pressure is small even far away from the speaker, the volume is not excessively loud in the area near the speaker. This helps suppress feedback (improving safety amplification gain).
- By joining 2 or 3 speakers, a longer sound source can be configured, making it possible to project sound output farther and at larger volumes.
- The speaker has a built-in network circuit for a single amplifier drive. Changing the internal connector position enables bi-amplifier drive that provides a higher quality sound output.
- The use of optional mounting brackets\* permits the speaker to be installed in the most appropriate position for its intended use. (Details of the installation procedures are described in the installation manual enclosed with each bracket.)
  - \* SR-WB4 Wall mounting bracket, SR-TB4 Wall tilt bracket, SR-FB4 Flying bracket, SR-SA4 Stand adapter, and SR-FS4 Floor stand.
- The speaker can be used for high-impedance applications with the additional use of the optional MT-S0601 Matching transformer. (Single-amplifier drive only)

## 4. COVERAGE AREA

The line array speaker radiates a sound only within a limited range. Since sound is reduced in areas that are outside the range, take care that the listening area is sufficiently covered when installing the speaker.

### • Correct installation examples

[SR-S4L x 2]

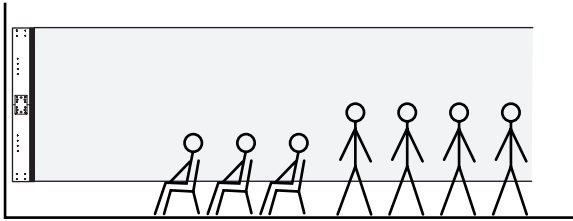

[SR-S4S]

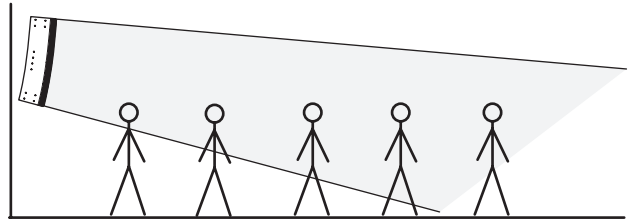

[SR-S4L + SR-S4S]

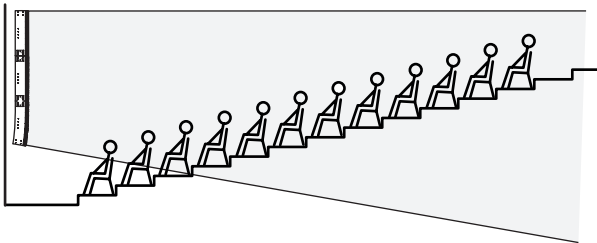

### • Incorrect installation examples

If the speaker is installed high above the floor facing horizontally or diagonally downward at a large angle, the listening area cannot be covered sufficiently.

[SR-S4L]



[SR-S4S]

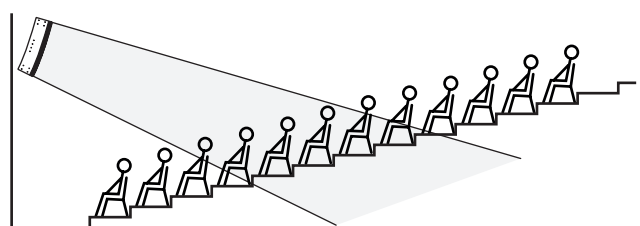

## 5. DIMENSIONAL DIAGRAM

### 5.1. Line Array Speaker SR-S4L

Unit: mm

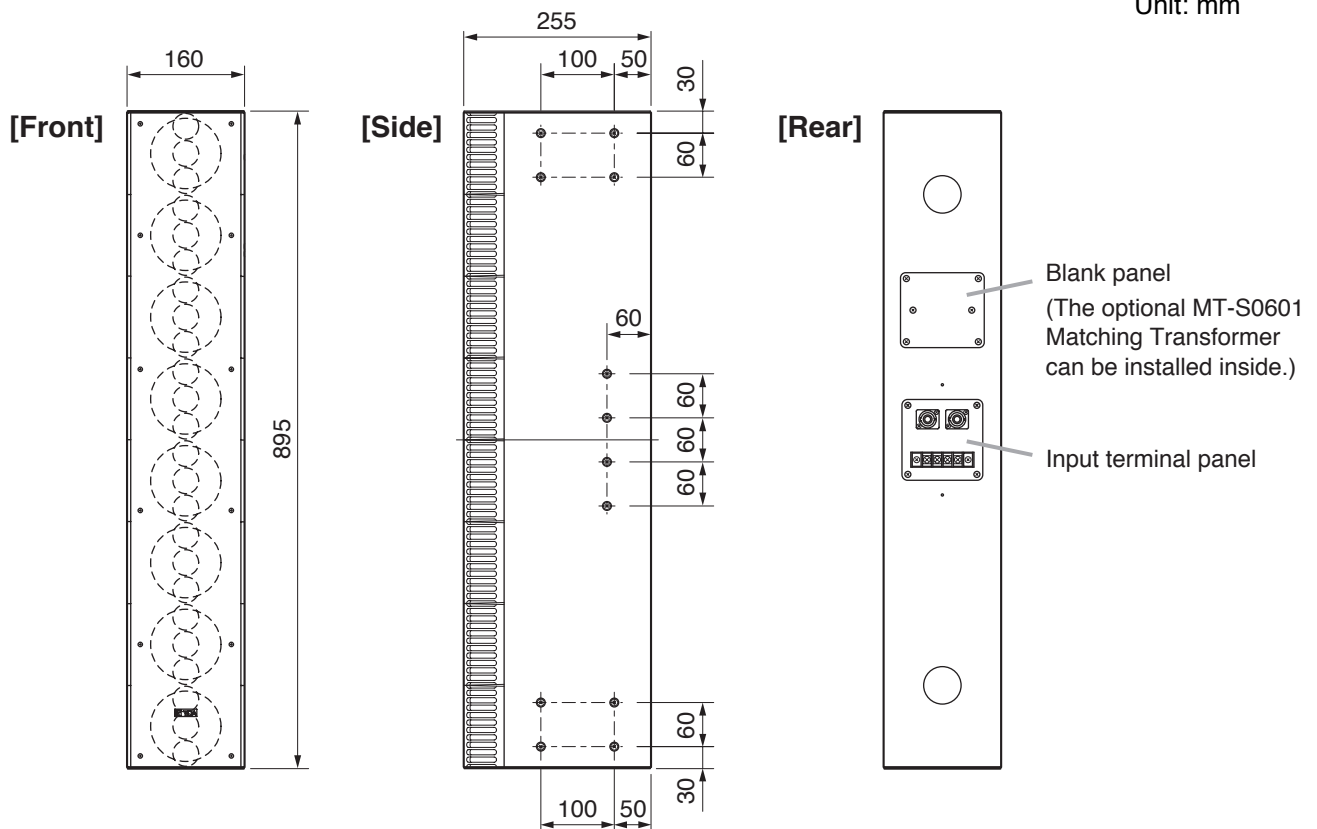

### 5.2. Line Array Speaker SR-S4S

Unit: mm

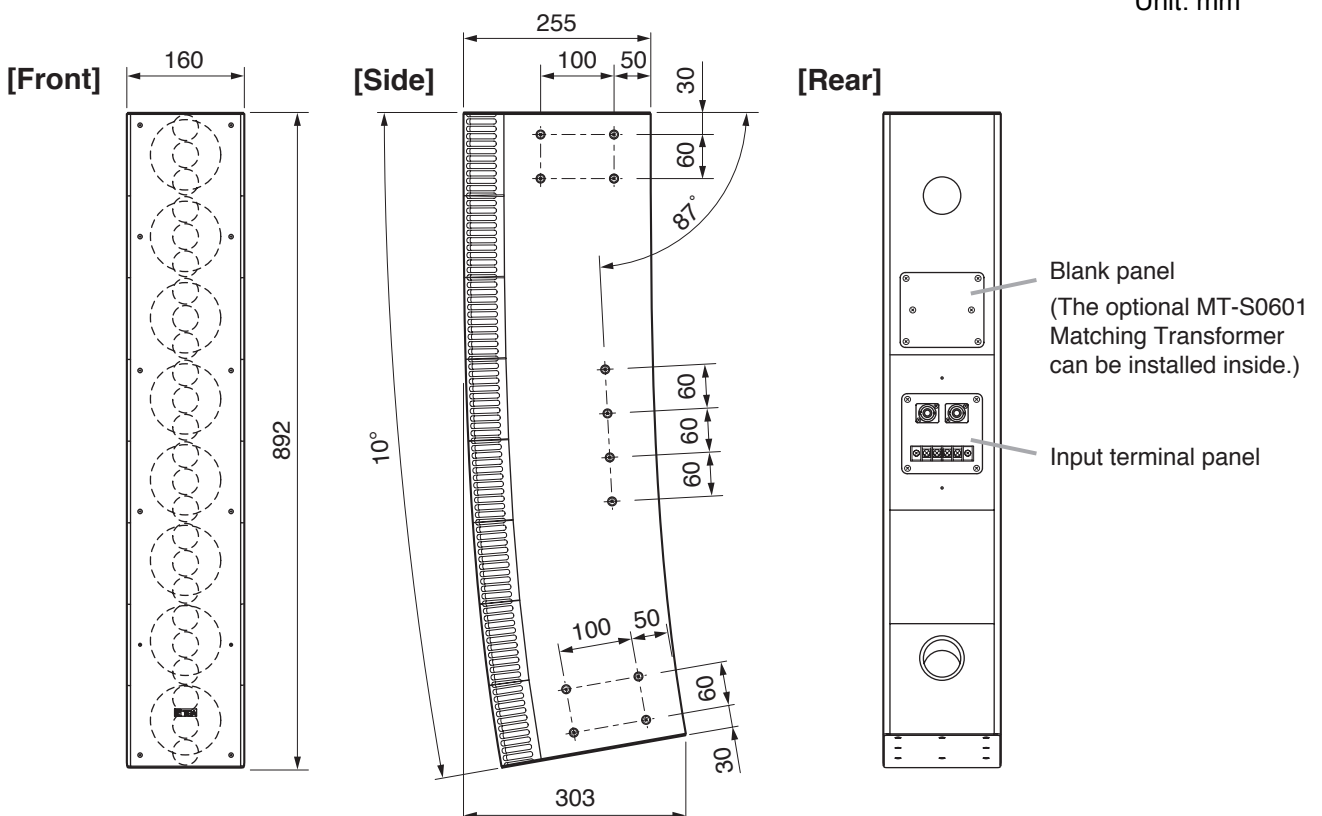

## 6. SINGLE-AMPLIFIER DRIVE AND BI-AMPLIFIER DRIVE

The SR-S4 series speakers are factory-preset to be driven by a single amplifier, however this setting can be changed to a bi-amplifier drive system by changing the speaker's internal wiring. (See p. 12; Changing Single-Amplifier Drive to Bi-Amplifier Drive System.)

### • Single-amplifier drive

**Note:** Use a digital processor as required.

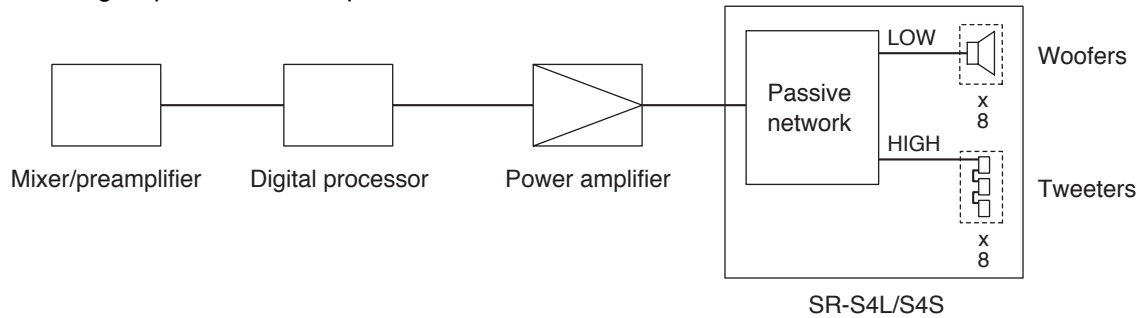

### • Bi-amplifier drive

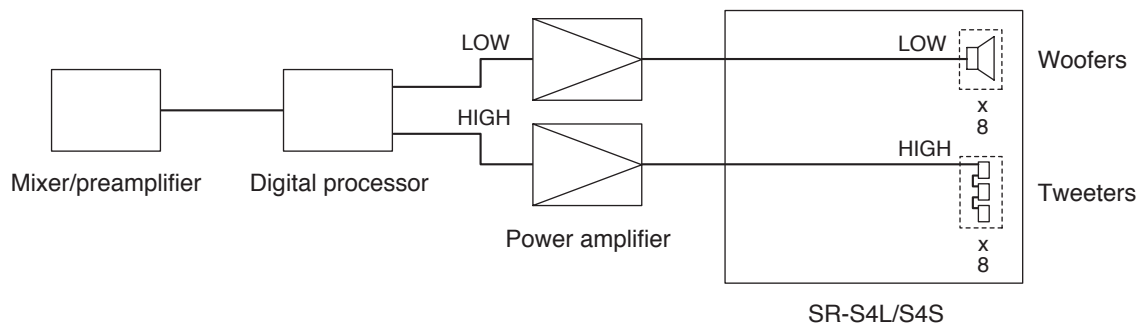

## 7. INTERNAL WIRING DIAGRAM

When shipped from the factory, the speaker is internally connected as shown below.

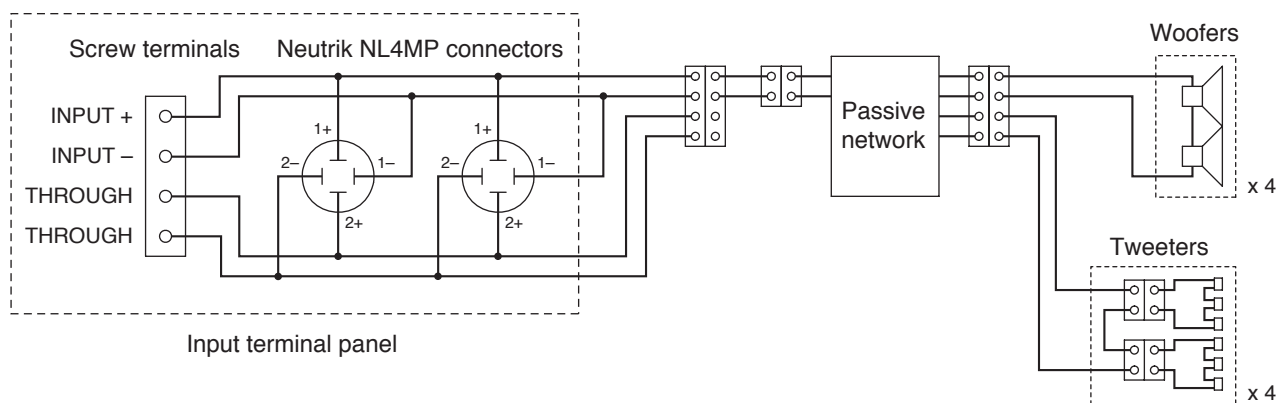

• Since the Neutrik NL4MP connectors and screw terminals are internally connected in parallel, either one can be used for connection.

• The Neutrik NL4MP connector's pins are wired as shown at right. The connector (connection cable side) suited to the Neutrik NL4MP is the Neutrik NL4FC.

Pin No.	SR-S4L, SR-S4S	Screw terminal indication
1 +	Speaker +	INPUT +
1 -	Speaker -	INPUT -
2 +	—	THROUGH
2 -	—	THROUGH



## 8. CHANGING TO HIGH IMPEDANCE

The SR-S4 series speakers can be used for high-impedance applications with the installation of the optional MT-S0601 Matching Transformer.

To install the MT-S0601 transformer, remove the blank panel located on the speaker's rear panel.

For details regarding mounting procedures, refer to the instruction manual enclosed with the MT-S0601.

### Note

The speaker cannot be used in combination with the matching transformer when driven by a bi-amplifier.

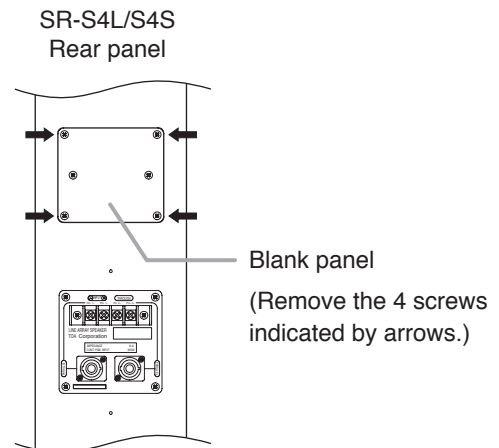

To change the tap, refer to the instruction manual enclosed with the MT-S0601.

Primary side impedance	High impedance 100 V line	High impedance 70 V line
83 $\Omega$	Unusable	60 W
170 $\Omega$	60 W	30 W
330 $\Omega$	30 W	15 W
670 $\Omega$	15 W	7.5 W

The diagram below is an internal wiring when the matching transformer is installed.

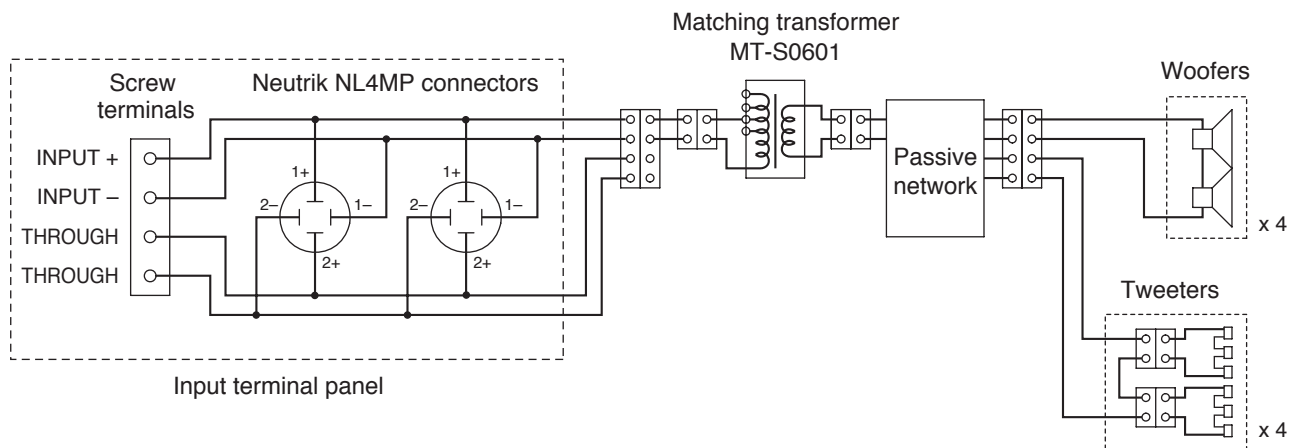

## 9. JOINING SPEAKERS

Joining line array speakers configures a longer linear sound source, permitting richer low-frequency sound reproduction as well as transmission of higher sound output over a longer distance. To join speakers, use the optional SR-EP4 Extension Plate.

### [Joining procedure]

**Step 1.** Remove the (M5 oval-head) screws on both sides of the speaker.  
The removed screws are no longer used.

**Step 2.** Join 2 speakers using the SR-EP4 Extension plate.  
Fix the plate to the speaker using the hex head bolts supplied with the SR-EP4.

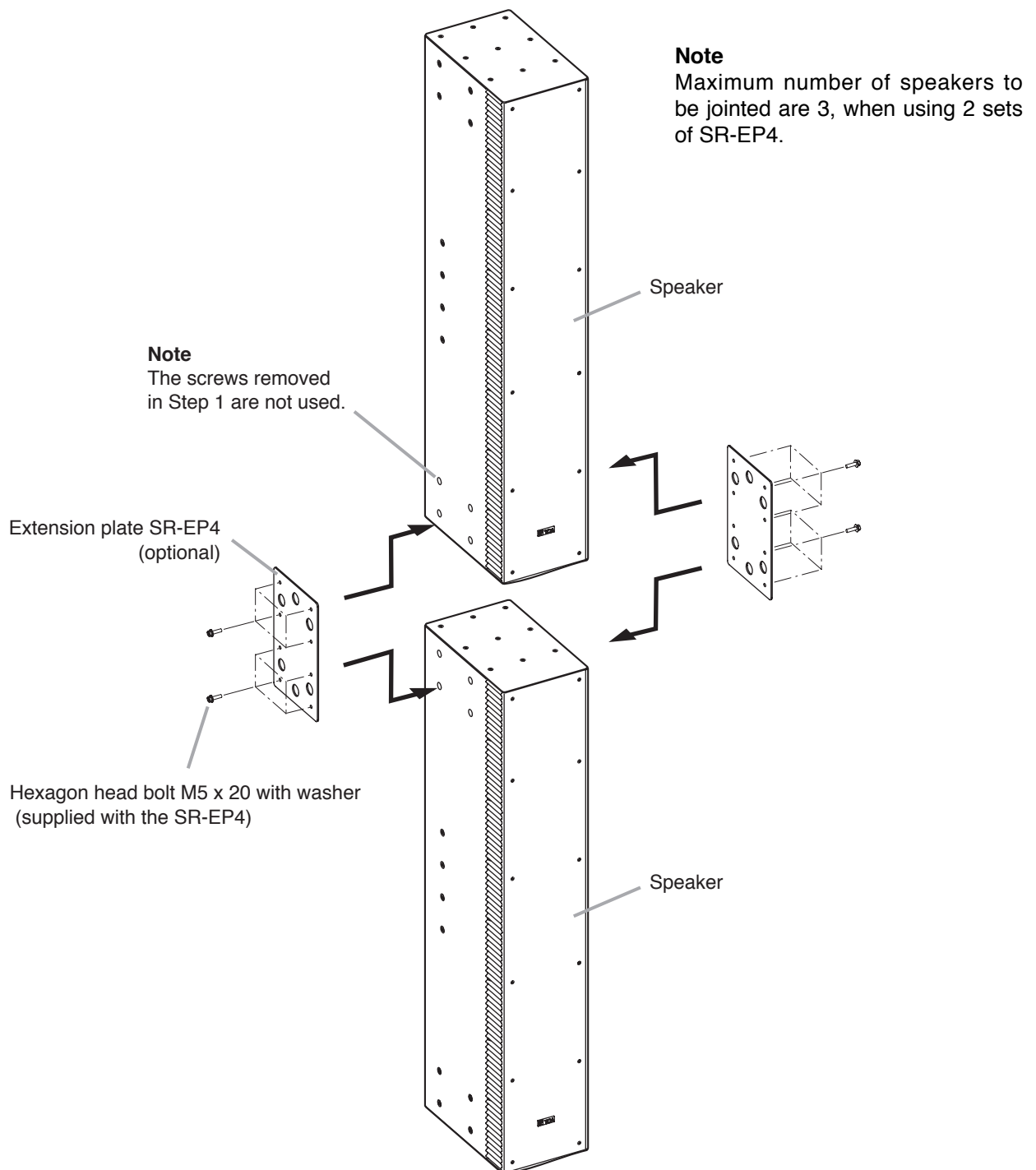

## 10. ATTACHING THE PROTECTION PAD TO THE SPEAKER EDGE

### **WARNING**

When installing the speaker at head height, attach the optional SR-RP4 Protection Pad to the speaker edges. If people should bump their heads directly against the corners or edges of the enclosure, injuries could result.

Remove the protective paper of the double-faced tape affixed to the SR-PP4 Protection Pad (optional) and attach the pad to the speaker edge as shown in the figure.

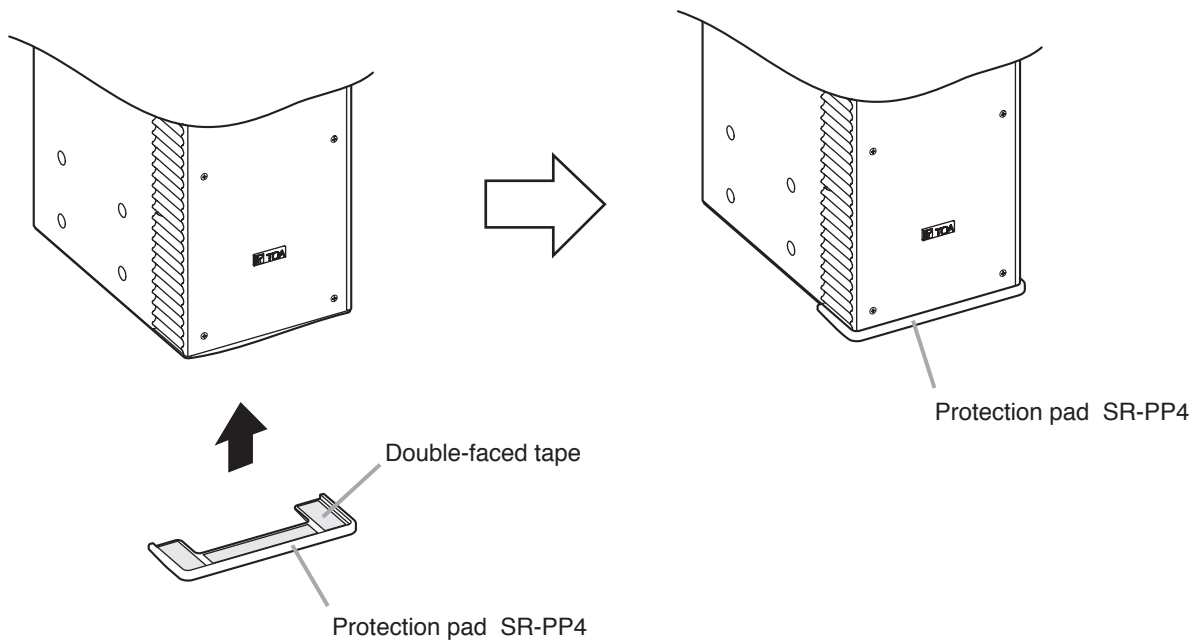

## 11. CHANGING SINGLE-AMPLIFIER DRIVE TO BI-AMPLIFIER DRIVE SYSTEM

The single-amplifier drive system can be changed to a bi-amplifier drive system by changing the speaker's internal wiring after removing the input terminal panel located at the back of the speaker.

### [How to change]

**Step 1.** Remove the 4 terminal panel mounting screws to remove the input terminal panel.

**Step 2.** Carefully pull out the short length of wiring connected to the back of the input terminal panel.

**Step 3.** Unplug 2 pairs of connected connectors, and reconnect them so that connections are made between labeled connectors and between unlabeled connectors.

**Step 4.** Reattach the input terminal panel to the speaker using the 4 screws.

**Step 5.** Affix the supplied label to the input terminal panel to change the indication.

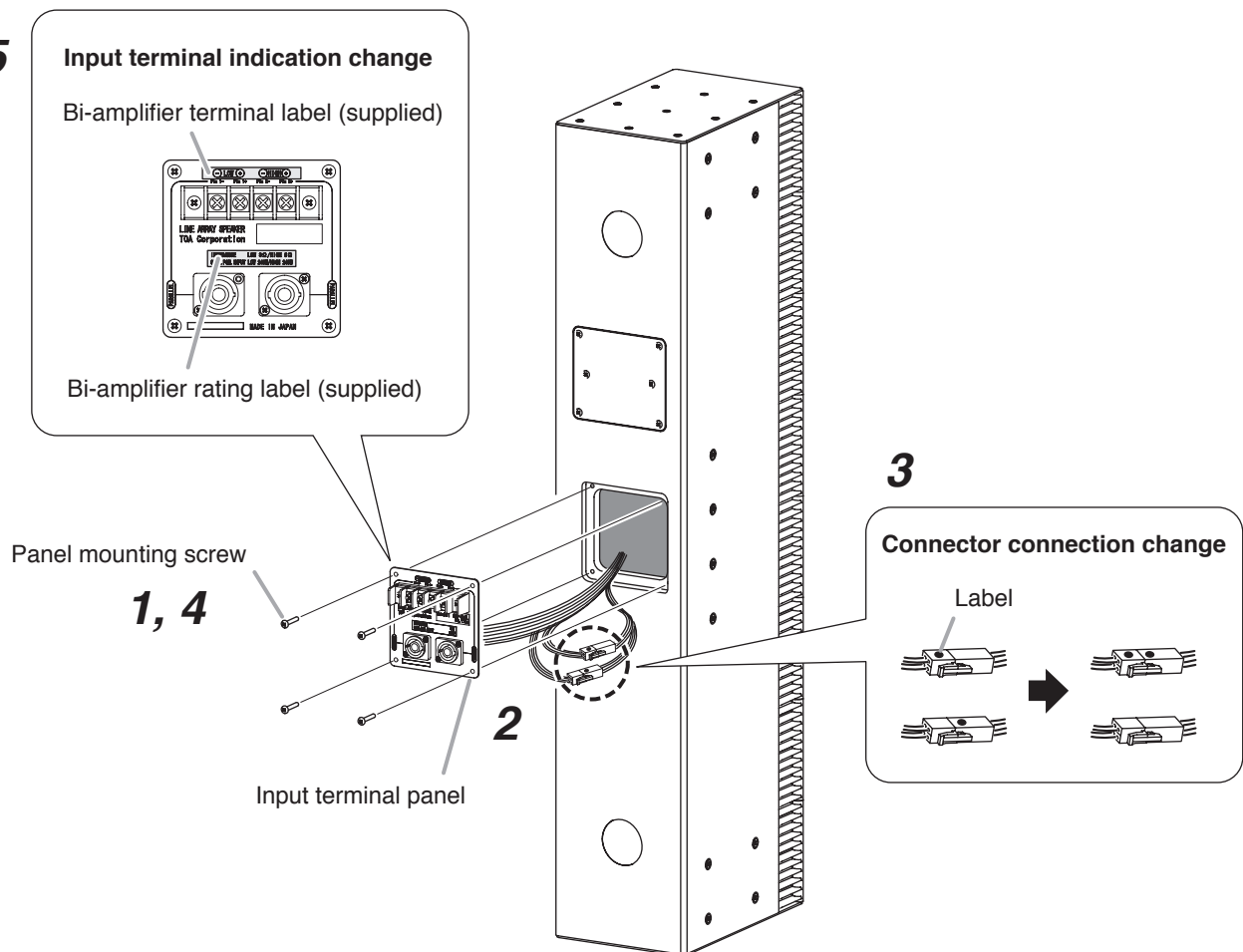

## 12. INTERNAL WIRING DIAGRAM FOR THE BI-AMPLIFIER DRIVE SYSTEM

The diagram below is an internal wiring after the speaker's drive system is changed to a bi-amplifier system.

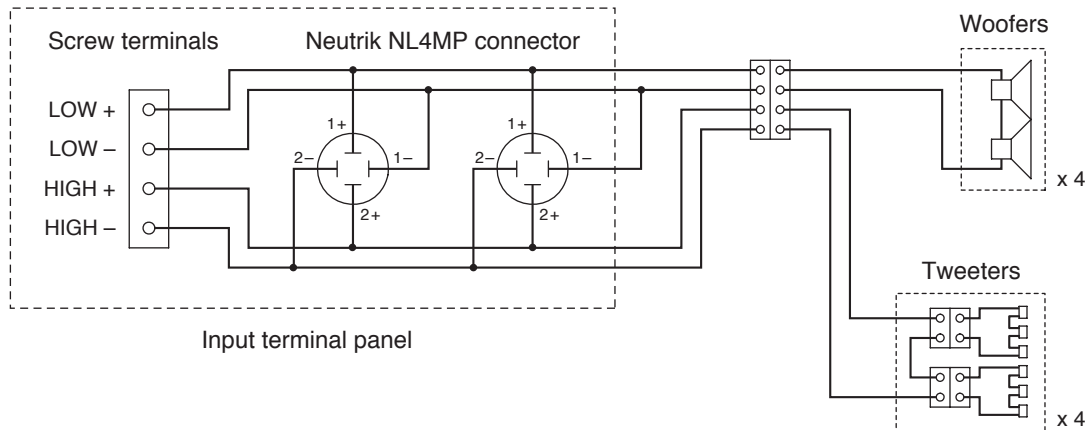

- Since the Neutrik NL4MP connectors and screw terminals are internally connected in parallel, either one can be used for connection.
- The Neutrik NL4MP connector's pins are wired as shown at right. The connector (connection cable side) suited to the Neutrik NL4MP is the Neutrik NL4FC.

Pin No.	SR-S4L, SR-S4S	Screw terminal indication
1 +	LOW +	LOW +
1 -	LOW -	LOW -
2 +	HIGH +	HIGH +
2 -	HIGH -	HIGH -

## 13. DIGITAL PROCESSOR FILTERING

### 13.1. Single-Amplifier Drive (Factory-Setting)

Although the speaker can be operated without a digital processor, it is recommended that the speaker be used in conjunction with a digital processor for better sound reproduction. Recommended setting parameters are as follows.

TYPE	Frequency	Gain	Q
HPF (12 dB)	60 Hz	—	1.226
PEQ	16 kHz	5 dB	1.414

### 13.2. Bi-Amplifier Drive

Digital processing is required after the drive system has been changed to bi-amplifier operation. By inputting an optimum signal to the woofer and tweeter using the digital processor, a high sound quality output can be realized. Recommended setting parameters are as follows.

Channel	Gain	Polarity	Filter				Delay
			TYPE	Frequency	Gain	Q	
LOW	0 dB	Normal	HPF (12 dB)	60 Hz	—	1.226	0 ms
			PEQ	63 Hz	2 dB	1.707	
			PEQ	1.5 kHz	-5 dB	0.700	
			LPF (12 dB)	4.0 kHz	—	0.500	
HIGH	-2 dB	Normal	HPF(12 dB)	4.0 kHz	—	0.707	0.125 ms
			PEQ	4.0 kHz	3 dB	2.997	
			PEQ	6.3 kHz	-3 dB	1.512	
			PEQ	16.0 kHz	5 dB	1.414	

# 14. SPECIFICATIONS

## 14.1. Line Array Speaker SR-S4L, SR-S4S

Model No.	SR-S4L	SR-S4S
Enclosure	Bass-reflex type	
Power Handling Capacity	Continuous program: 600 W	
Rated Impedance	8 Ω	
Sensitivity	94 dB (1 W, 1 m)	93 dB (1 W, 1 m)
Frequency Response	70 – 20,000 Hz (when using the optional DP-0206 Digital processor)	
Crossover Frequency	3,500 Hz	
Directivity Angle	Horizontal: 90° Vertical: 0° (within the range of speaker height)	Horizontal: 90° Vertical: 10°
Speaker Component	Low frequency: 10 cm cone-type x 8 High frequency: 2.5 cm balanced dome-type x 24	
Input Connector	M5 screw terminal, distance between barriers: 12.2 mm and Neutrik NL4MP x 2 (usable cable connector: Neutrik NL4FC)	
Finish	Enclosure: MDF, white, paint Front grille: Punched steel plate, white, acrylic paint	
Dimensions	160 (w) x 895 (h) x 255 (d) mm	160 (w) x 892 (h) x 303 (d) mm
Weight	16 kg	

**Note:** The design and specifications are subject to change without notice for improvement.

• **Accessories**

Bi-amplifier rating label ..... 1  
Bi-amplifier terminal label ..... 1

• **Optional products**

Matching transformer: MT-S0601  
Extension plate: SR-EP4  
Flying bracket: SR-FB4  
Wall tilt bracket: SR-TB4  
Wall mounting bracket: SR-WB4 (Applicable to the SR-S4L only)  
Floor stand: SR-FS4 (Applicable to the SR-S4L only)  
Stand adapter: SR-SA4  
Protection pad: SR-PP4  
Digital processor: DP-0206

## 14.2. Extension Plate SR-EP4 (optional)

The SR-EP4 is used to join multiple SR-S4L or SR-S4S speakers. One complete set consists of 2 brackets.

Number of Speaker to be Jointed	Max. 3 (when using 2 sets of SR-EP4)
Finish	Steel plate, white, paint
Dimensions	140 (w) x 220 (h) x 2.3 (t) mm
Weight	1.1 kg (including accessories)

**Note:** The design and specifications are subject to change without notice for improvement.

### • Accessories

Hexagon head bolt M5 x 20 with washer ..... 16

## 14.3. Protection Pad SR-PP4 (optional)

When the SR-S4L or SR-S4S speaker is installed so that its bottom edge is located at head height, people could bump their heads directly against the speaker and suffer injuries. Affixing this protection pad to the speaker's bottom surface helps reduce the impact and chance of injury.

Finish	Synthetic rubber, black
Dimensions	168 (w) x 59 (d) x 8 (t) mm
Weight	40 g

**Note:** The design and specifications are subject to change without notice for improvement.