

■DESCRIPTION

The ER-1000 is a compact, lightweight, hands-free portable public address system with a rated power output of 6 W (9 V DC when used with six AA-type batteries).

The system can be wrapped snugly around the waist and using the supplied headset microphone allows both hands to remain free, making it ideal for such applications as conducting factory tours, directing traffic, instructing in sports facilities, and security-and-safety-related applications.

■SPECIFICATIONS

(*1) 0 dB = 1 V

Power Source	Alkaline battery (LR6): 6 pieces (9 V DC) or 4 pieces(*2) (6 V DC) Rechargeable nickel metal hydride (Ni-MH) battery (HR15/51): 6 pieces (7.2 V DC) or 4 pieces(*2) (4.8 V DC) Black manganese battery (R6PU): 6 pieces (9 V DC) or 4 pieces(*2) (6 V DC)
Output	6 W (rated) and 10 W (max) when 6 AA batteries (9 V DC) are used. 3 W (rated) and 4 W (max) when 4 AA batteries(*2) (6 V DC) are used.
Battery Life	Voice operation(*3): Approx. 8 hours (when 6 or 4(*2) alkaline batteries are used) AUX stereo input operation (music reproduction)(*4): Approx. 4.5 hours (when 6 or 4(*2) alkaline batteries are used) Approx. 5.5 hours (when 6 or 4(*2) Ni-MH batteries are used) Approx. 3 hours (when 6 or 4(*2) black manganese batteries are used)
Audible Range(*5)	Voice operation: Approx. 80 m (87.49 yd) (when 6 alkaline batteries or Ni-MH batteries are used) Approx. 40 m (43.74 yd) (when 4(*2) alkaline batteries or Ni-MH batteries are used) Note: The audible range when black manganese batteries are used is approximately 80 % of each of the above mentioned distances.
Frequency Response	300 Hz - 14 kHz (deviation: -26 dB)
Headset Microphone	Ear-on type, electret condenser microphone, sensitivity: -47 dB (0 dB = 1 V/1 Pa, 1 kHz)
Input	MIC: -30 dB(*1), 3 kΩ, Ø3.5 (0.14") monaural mini-jack, phantom power supply AUX(*6): -10 dB(*1), 2 kΩ, Ø3.5 (0.14") stereo mini-jack (supporting monaural applications(*7))
Belt Length	55 - 120(*8) cm (1.80 - 3.94(*8) ft) 90 - 160(*9) cm (2.95 - 5.25(*9) ft) (when wearing a extension belt (accessory))
Operating Temperature	0 °C to +40 °C (32 °F to 104 °F)
Finish	Front case: ABS resin, light grayish purple Rear case: ABS resin, dark grayish purple Grille: Surface-treated steel plate, dark grayish purple, paint Belt: Elastic rubber, black
Dimensions	133 (W) × 96 (H) × 222 (D) mm (5.24" × 3.78" × 8.74") (belt excluded)
Weight	Main PA unit (belt included, batteries excluded): 480 g (1.06 lb) Headset microphone: 50 g (0.11 lb) Extension belt: 40 g (1.41 oz)
Accessory	Headset microphone (with headband and wind screen) ...1, Belt (attached to the main PA unit) ...1, Extension belt ...1, Battery spacer ...2

(*2) When the supplied battery spacers are used.

(*3) Battery life during voice output usage represents the period of time when the Personal PA System is continuously used with the volume control set to a position that does not cause feedback.

Reference standard: JEITA (Japan Electronics and Information Technology Industries Association) TT-4501B

(*4) Battery life during AUX stereo input represents a value actually measures when music is continuously reproduced with a commercial audio player connected to the auxiliary (AUX) input terminal. It varies depending on the connected external equipment's volume output or the type of music source.

(*5) Audible range is measured on a quiet street with the Personal PA System loaded with fresh batteries. Range varies depending on surrounding environmental conditions, such as battery consumption, ambient noise levels, wind direction and obstacles. (Reference standard: JEITA TT-4501B)

(*6) Adjust the volume of the auxiliary (AUX) input at the connected external device.

(*7) Volume during monaural operation is smaller than during stereo operation.

(*8) The 120 cm (3.94 ft) length is when the Belt is stretched out to its maximum extent. When worn, consider a Belt length of 100 cm (3.28 ft) (of waist size when clothes are worn) as a rule-of-thumb standard.

(*9) The 160 cm (5.25 ft) length is when the Belt is stretched out to its maximum extent. When worn, consider a Belt length of 150 cm (4.92 ft) (of waist size when clothes are worn) as a rule-of-thumb standard.

Note: Prepare batteries separately, as they are not supplied with the product.

■ APPEARANCE

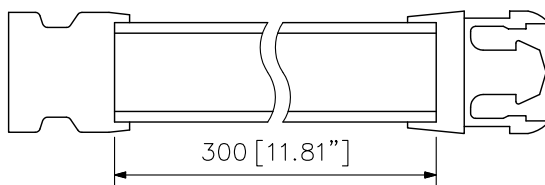
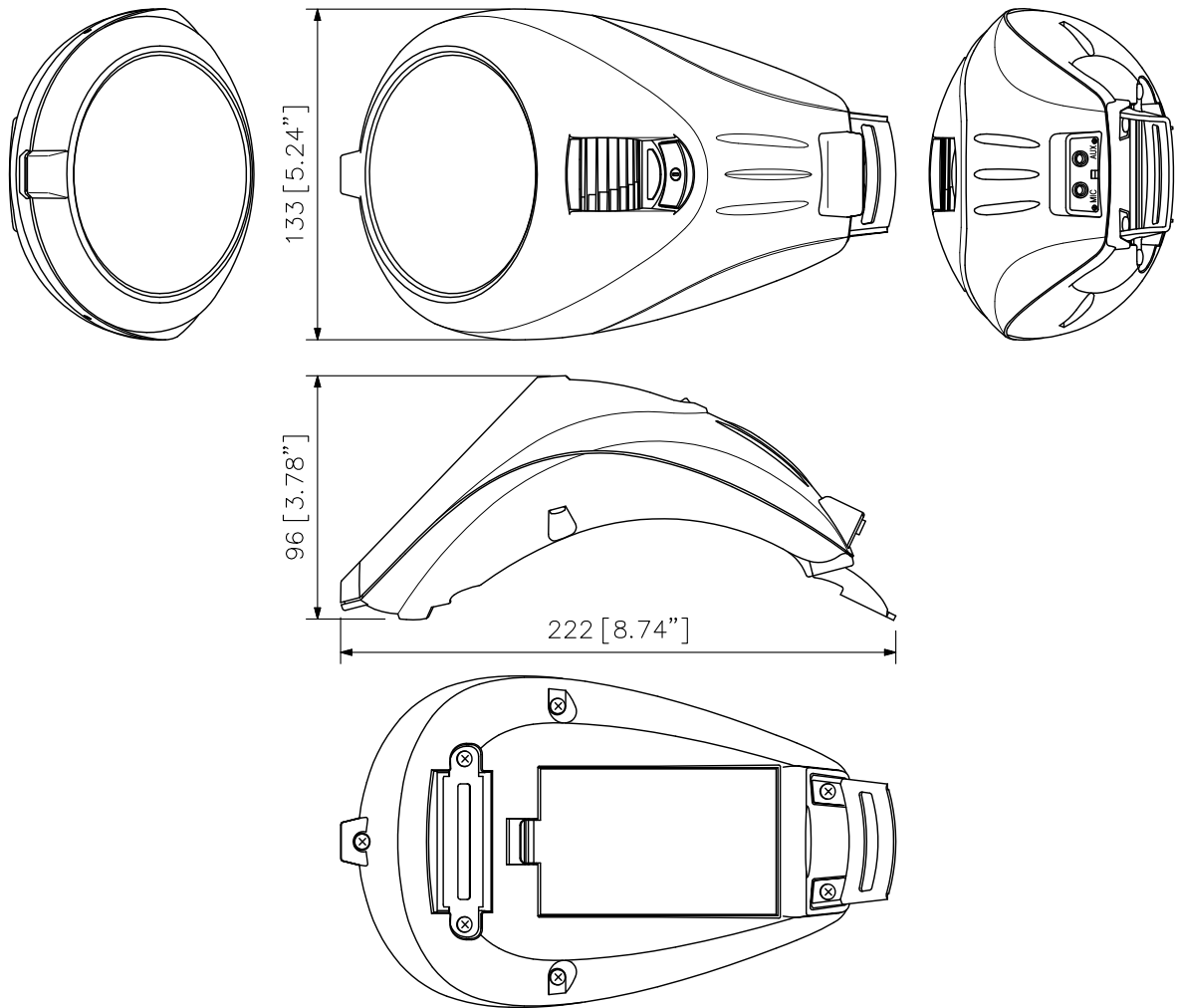

Extension belt (accessory)

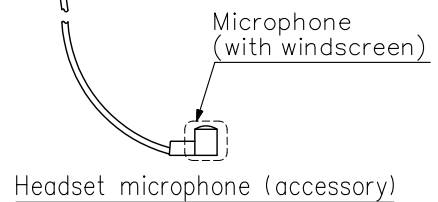

Headset microphone (accessory)

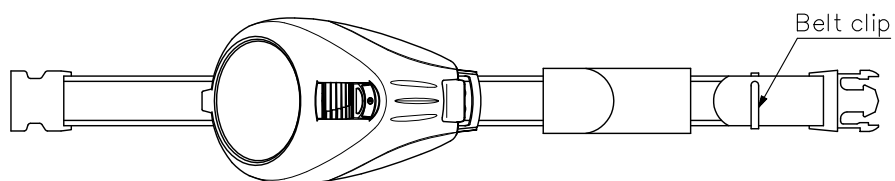

Figure with the supplied belt attached
(scale: 1/6)

UNIT:mm SCALE:1/3