



**N-XC65-W**

**IP Audio  
Window Intercom Kit**



**Full Duplex High Definition Sound,  
Clear Interference Free Communication**

# IP Audio Window Intercom Kit

Suitable for two-way communication for banking counters, airports or information centres, the N-XC65-W IP Audio Window Intercom Kit offers a stylish, high performance option when speech is impaired by glass or other obstruction.

Its single digital signal processor multi-channel acoustic technology effectively tunes out interference resulting in high voice intelligibility. The terminal is capable of identifying sound sources at the same time while suppressing environment noise and automatically adjusting sound volume.

- Duplex Class D amplifier
- Touch key
- Three possible listening modes (quiet / standard / noisy)
- Professional design with hard metal structure preventing machine resonance
- Speaker and microphone
- IP Control
- Analog output on the interface to record conversation
- Support dual recording mode (analog & digital)

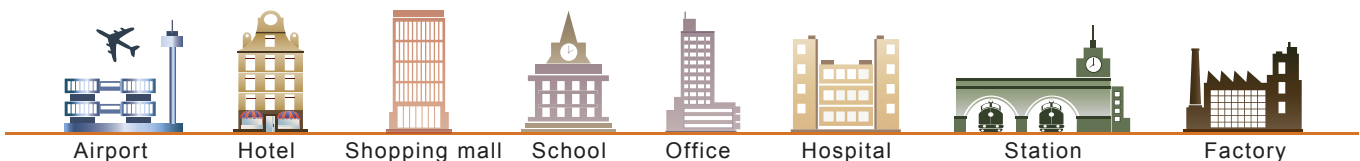

## Digital Window Intercom

**Network Technology, Clear Communication.**

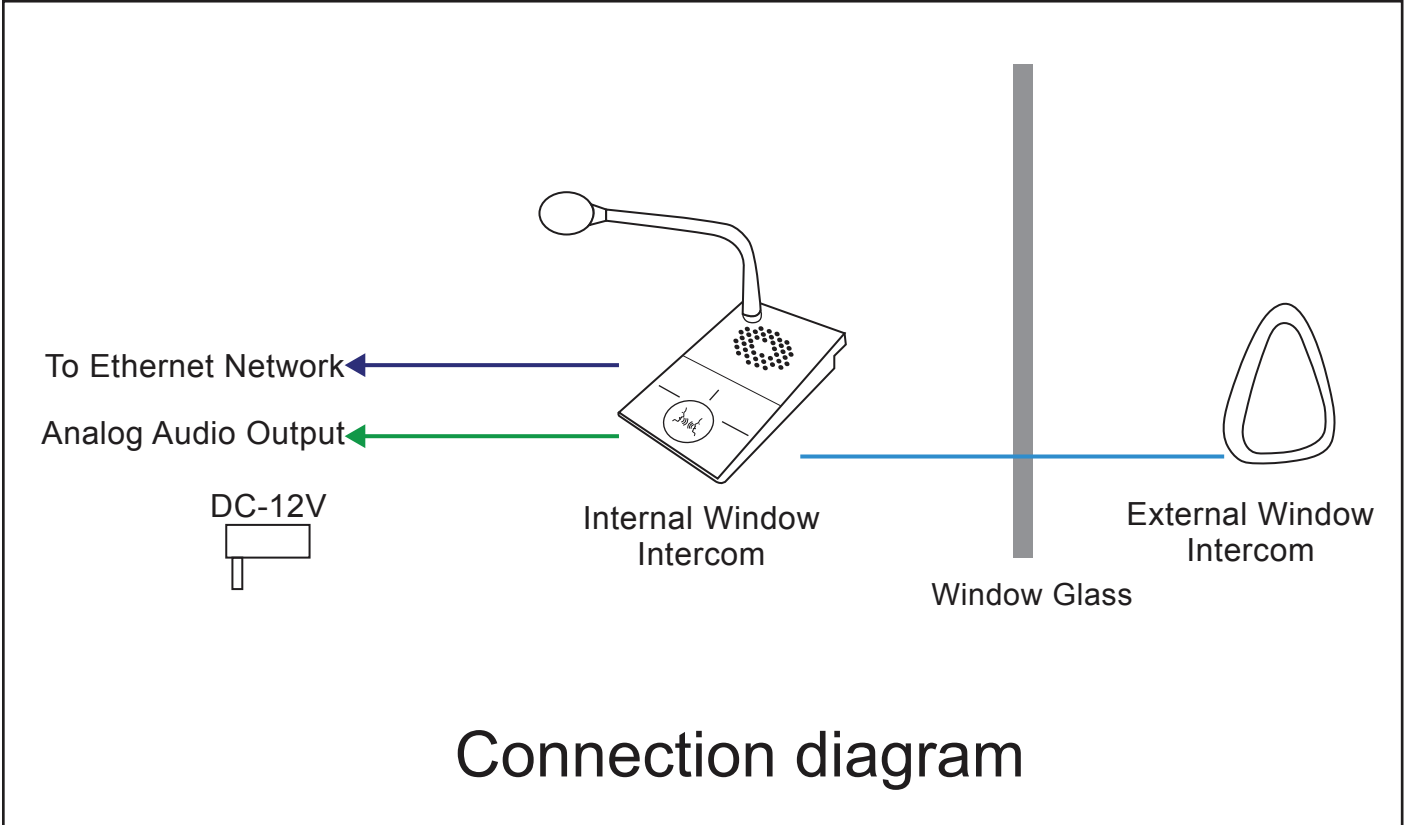

Connection diagram

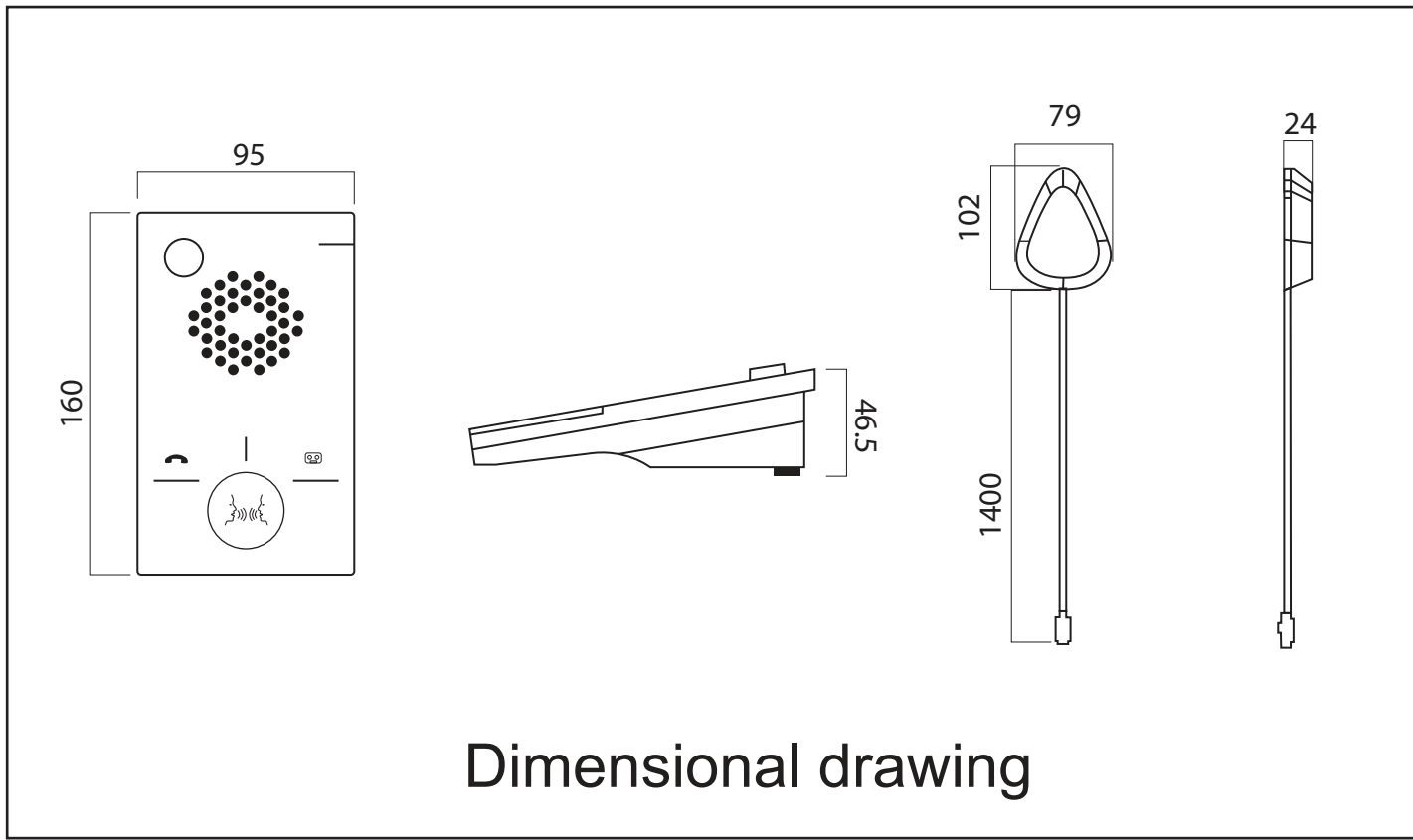

Dimensional drawing

## SPECIFICATIONS

MODEL	N-XC65-W
Power Supply	DC 12V 1.5A
Consumption	≤ 5W
Network Protocol	TCP/IP, UDP, ARP, ICMP, IGMP, FTP
Audio Code	PCM/AAC
Audio Sampling	8 KHz - 32 KHz
S/N	> 90 dB
Frequency Response	20 Hz - 16 KHz
Interface	1x RJ45, 1x Power Supply port, 1x External Unit, 1x Rec out
Working Temperature	-20°C - 60°C
Humidity	≤ 90% RH (Not condensing)
Dimensions	Internal unit 160 x 95 x 46.5mm External unit 83 x 24mm
Weight	Internal Unit 0.44 kg External Unit 0.20 kg