

TOA POWERED MIXER

Model MX-601

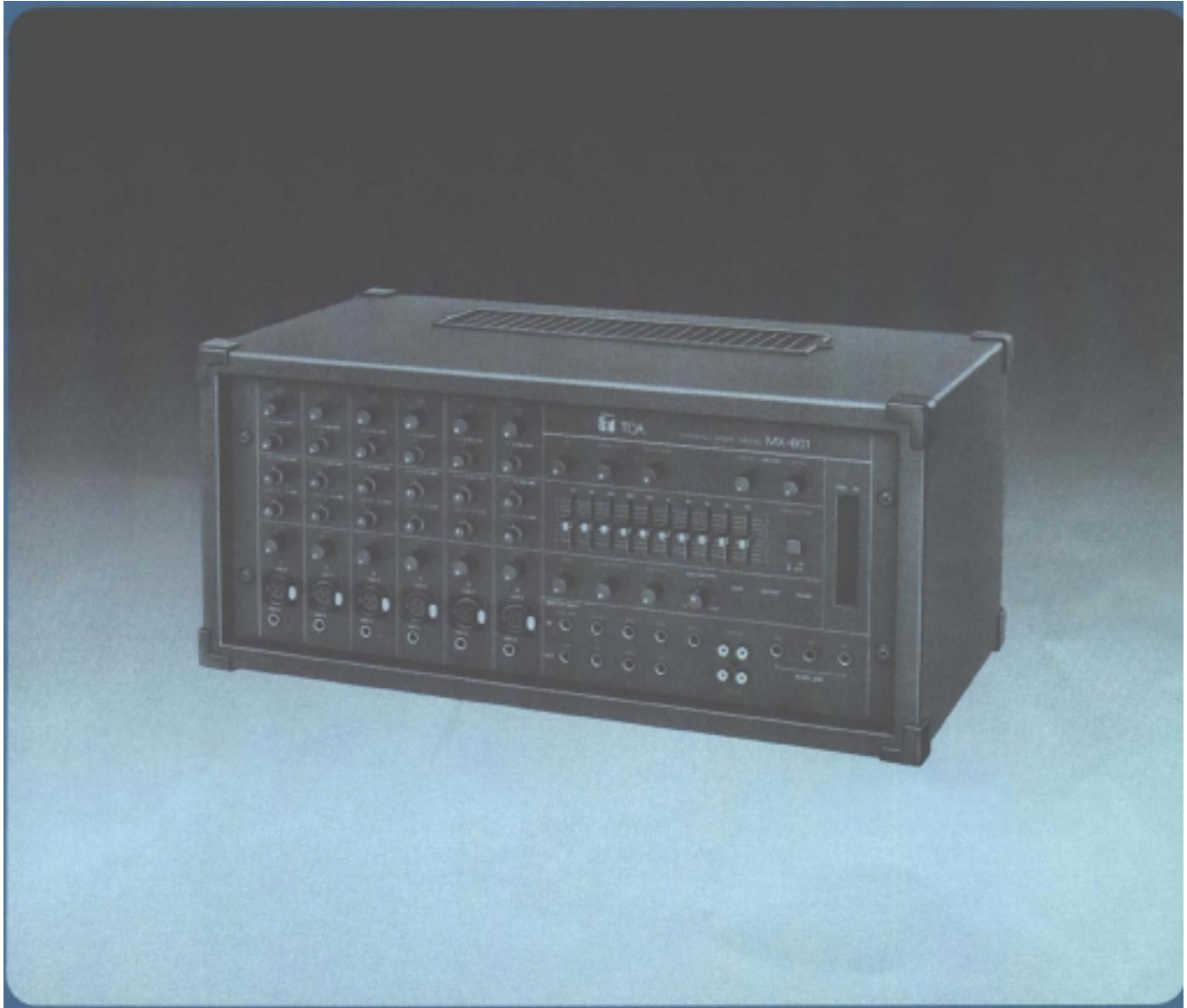

● Contents

General Description	2
Features	2
Front Panel [Names of components & their usage]	3
Rear Panel [Names of Components & their usage]	4
Connection Examples	5
Input Connections	6
How to get a good mix	7
Block and Level Diagrams	8
Specifications	9
Characteristics Diagrams	10
Appearance	10

● Precautions

1. XLR Type Audio Connector

The connectors are wired as follows.

The pin 1 is ground (shield,) the pin 2 cold (low, minus), the pin 3 hot (high, plus.)

2. Description of components and functions on the MX-601

Various descriptions are applied, depending on each manufacturer. In our Operating and Instruction Manual explanation of components and functions is made according to our usage for them.

● General Description

The MX-601 is a compact self-powered mixer with a wide array of sophisticated features — many of them unavailable on any competitive models. An examination of performance levels and specifications will reveal the truly professional nature of the MX-601. The rugged construction and specialized packaging ensure optimum performance and reliability under even the most demanding "on the road" applications.

The MX-601 features 6 input channels; 1 program, 1 foldback, and 1 effects output. The internal power amplifier is rated at 120 watts into 8 ohms, 200 watts into 4 ohms, and 300 watts into 2 ohms load.

Each input channel features an electronically balanced XLR connector, and a high impedance unbalanced 1/4" phone jack. An input trim control is provided to accommodate a wide range of input source levels. A peak indicator LED detects excessive input signal (either pre or post EQ), aiding in proper settings of the trim control to avoid input clipping.

Each channel also features 4-band equalization, a "pre" foldback send, a "post" reverb/effects send, and program level control.

The master control section features a one-octave (10-band) graphic equalizer, high and low equalizer control of an internal reverberation unit, auxiliary input controls, LED bargraph output meters, and a full patch bay with our exclusive Bus-Link capability. All master level controls, and effects return to program and foldback busses are also contained in this section.

● Features

1. Six Input channels
2. 300 watts RMS (@ 2 ohms)
3. 10-band graphic equalizer w/bypass switch
4. Auto Comp compression circuitry w/indicator
5. Built-in spring reverberation unit
6. LED bargraph metering
7. Power amp protection circuitry w/indicator
8. Complete patch bay w/buss link
9. AUX and TAPE inputs w/pan and level controls
10. Reverb-effects return to PGM and FB
11. Independent foldback mix
12. Input Channels 5 and 6 have electronically balanced XLR mic input connector with switchable 40 volts phantom power

Each Channel

1. Input trim control w/LED peak indicator
2. Pre EQ foldback send
3. 4-band EQ
4. Post effects send
5. Lo-Z balanced XLR input
6. Hi-Z unbalanced 1/4" input

● Front Panel

Peak Indicator (PEAK)
The peak indicator lights when the pre or post EQ signal level reaches 3dB below clipping, giving a visual reference for optimum setting of the trim control.

Foldback Control (FB)
The Foldback control determines the level of signal assigned to the foldback mixing buss, thus setting the level of that channel in the on-stage monitor mix.

Reverb/Effects Control (REV/EFF)
This control determines the level of signal assigned to the reverb effects buss. Rotating the control clockwise increases the amount of reverb effect in that channel.

High Equalizer Control (High)
The high EQ control provides ± 15 dB of continuously variable shelving equalization at 20 kHz, and has a flat audio response when set to the "0" detented position.

High-Mid Equalizer Control (HIGH MID)
The high-mid EQ control provides ± 13 dB of continuously variable peaking equalization at 3kHz, and has a flat audio response when set to the "0" detented position.

Low-Mid Equalizer Control (LOW MID)
The low-mid EQ control provides ± 13 dB of continuously variable peaking equalization at 300Hz, and has a flat audio response when set to the "0" detented position.

LOW Equalizer Control (LOW)
The low EQ control provides ± 15 dB of continuously variable shelving equalization at 30Hz, and has a flat audio response when set to the "0" detented position.

Input Level Control (LEVEL)
The level control provides continuously variable adjustment of the channel output to the program mixing buss, thus determining the level of that channel in the main sound system mix. Since the reverb/effects signal is "post" this control, an increase in the level of the channel's output will also result in a corresponding increase in the reverb effect of that channel. The nominal level of the input level control is at the "0" position.

Low Impedance Connectors (LOW Z)
The XLR connectors are low impedance, electronically balanced inputs with an input impedance of 1k ohms.

Input Trim Control (TRIM)
The input trim adjusts the gain of the head-amp stage of the associated channel, providing 39dB of gain control. When the trim control is set to the "0" position, the nominal input levels of the low-Z and high-Z inputs are -55dB and -35dB respectively. At the "-30" position the levels are -16dB and +4dB. The trim of each channel should be adjusted so that the peak LED just begins to light, or only flashes occasionally. This will ensure lowest distortion levels and optimum signal to noise ratio.

Foldback Master Control (FB)
The FB master control adjusts the overall combined signal level of the six independent channel foldback sends, and thus the level of the entire on-stage monitor mix.

Reverb/effects to Foldback Control (REV/EFF TO FB)
This control adjusts the amount of reverb/effects signal that is returned to the foldback buss and thus the level of reverb/effects contained in the on-stage monitor mix.

Reverb/Effects Send Control (REV/EFF SEND)
This control adjusts the overall signal level of the effects mix that is delivered to the internal reverberation unit, or to an external effects device through the effects output. The send control works in conjunction with the REV/EFF to PGM and the REV/EFF to FB controls to set the overall level of reverb/effects in the main and monitor sound systems.

Reverberation High Equalizer Control (HIGH EQ)
The high EQ control alters the high frequency response of the reverberation signal. The "0" detented position provides flat audio response.

Reverberation Low Equalizer Control (LOW EQ)
The low EQ control alters the low frequency response of the reverberation signal. The "0" detented position provides flat audio response.

Equalization LED Indicator (EQUALIZATION)
The LED indicator lights when the equalization switch is set to "IN" position.

Graphic Equalizer In/Out Switch (IN/OUT)
The in/out switch enables comparison between a flat response (out) and the equalized response (in). The "out" position completely removes the equalizer from the MX-601 circuitry.

LED Bargraph Peak Meters (PGM/FB)
The high intensity meters enable visual monitoring of the program and foldback output signal levels.

Power LED Indicator (POWER)
The LED indicator lights when the power switch is set to "ON" position.

Power Amp Protection Indicator (PROTECT)
The indicator LED lights if the power amplifier output is shorted, if the temperature of the unit rises above acceptable levels, or if DC is drifted to the speaker outputs. If the LED should light, speaker wiring and ambient temperature of the MX-601 should be checked. If the LED remains lighted, the unit should be referred to qualified service personnel for repair.

Note:
The MX-601 protection circuitry will (1) detect faulty conditions within the power amplifier, (2) give a visual indication, and (3) automatically shut down until the fault condition is alleviated. This special circuitry ensures maximum reliability and virtually eliminates equipment damage due to unsafe or fault conditions. Please refer to fault protection table on page 7 for full explanation of this important feature.

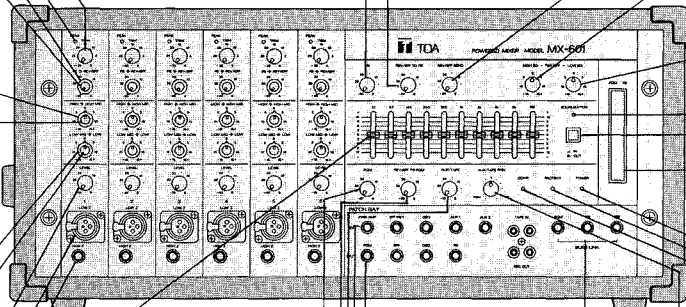

Graphic Equalizer (EQUALIZATION)
The graphic equalizer is 1/1 octave with 10 independent active bands (filters), providing 12dB of boost or cut at each center frequency. The "0" detented position provides flat audio response.

High Impedance Connectors (HIGH Z)
These connectors are unbalanced, standard 1/4" phone jacks with an input impedance of 50k ohms, and an input level of -35dB when the trim control is set to "0". When a plug is inserted into the high-Z input, the corresponding XLR connector is automatically switched out of the input circuitry.

Program Master Control (PGM)
The PGM control adjusts the overall combined signal level of the six independent channel level controls, and thus the level of the main sound system.

Reverb/Effects to Program Control (REV/EFF TO PGM)
This control adjusts the amount of reverb/effects signal that is returned to the program buss and thus the level of reverb/effects contained in the main sound system.

Aux/Tape Level Control (AUX/TAPE)
This control sets the overall level of the AUX/TAPE input signal.

Buss Link Jack (BUSS LINK)

Patching Jack (PATCH BAY/OUT)

Patching Jack (PATCH BAY/IN)

Aux/Tape Panpot (AUX/TAPE PAN)
This control assigns the auxiliary and tape input signal (a tape deck, etc., connected to the aux input jacks) to either the program or the foldback mixing busses. At the center position, the signal is routed equally to both busses. Panning from one side to the other gradually assigns the signal to either independently.

Power Amp Compression Indicator (COMP)
The Comp LED lights when the internal compressor is activated. The compressor is provided to protect speaker systems by compressing the input signal level of the power amplifier when clipping occurs in the output stage. Frequent flashing of the LED is not reason for alarm. However, a constant or steady light indicates that the MX-601 is being overdriven and that the internal power amplifier is possibly "under powered" for that application. The output level of the MX-601 should be decreased until the LED only flashes intermittently.

● Front Panel, Patch Bay & Buss Link

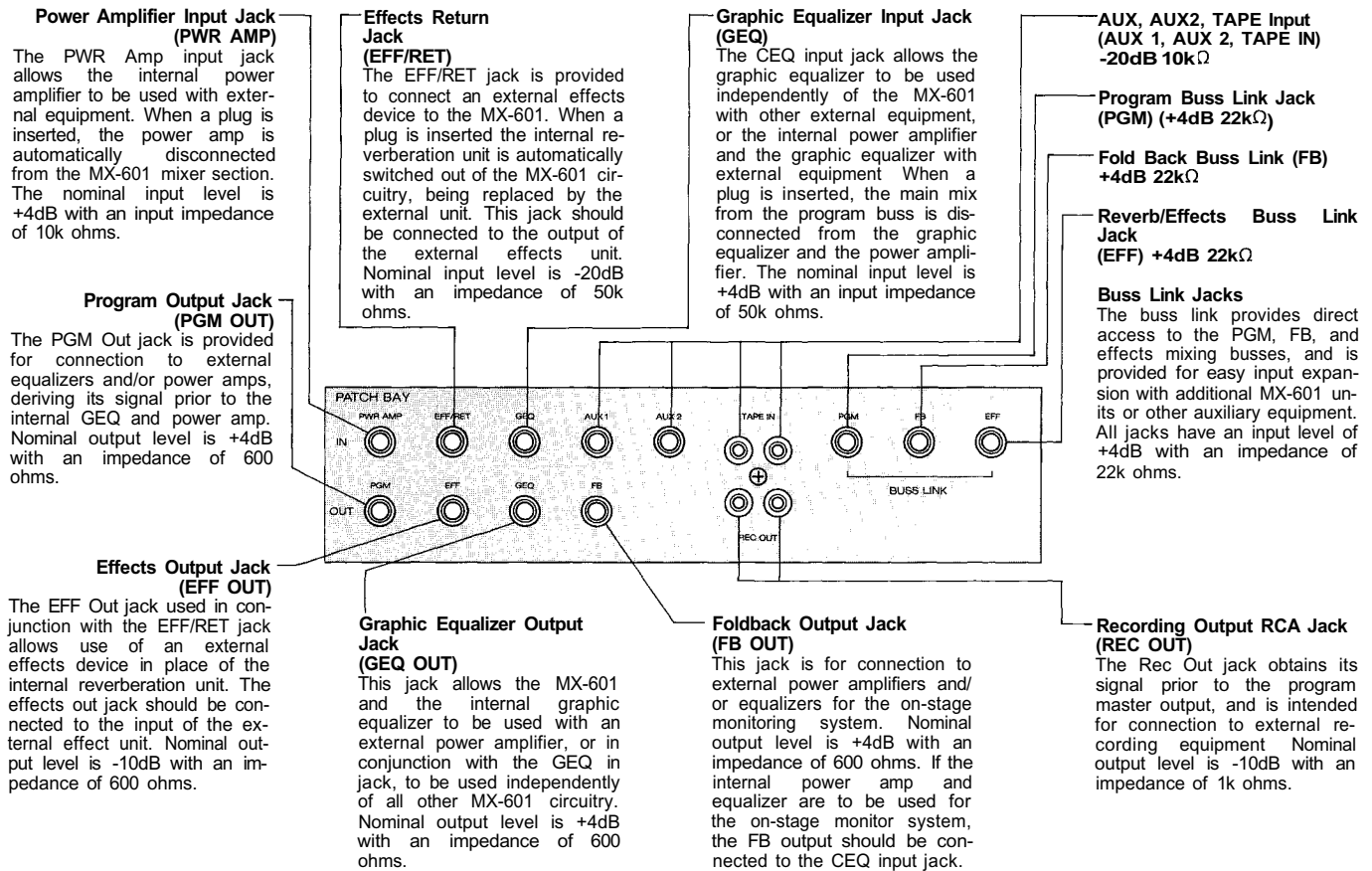

● Rear Panel

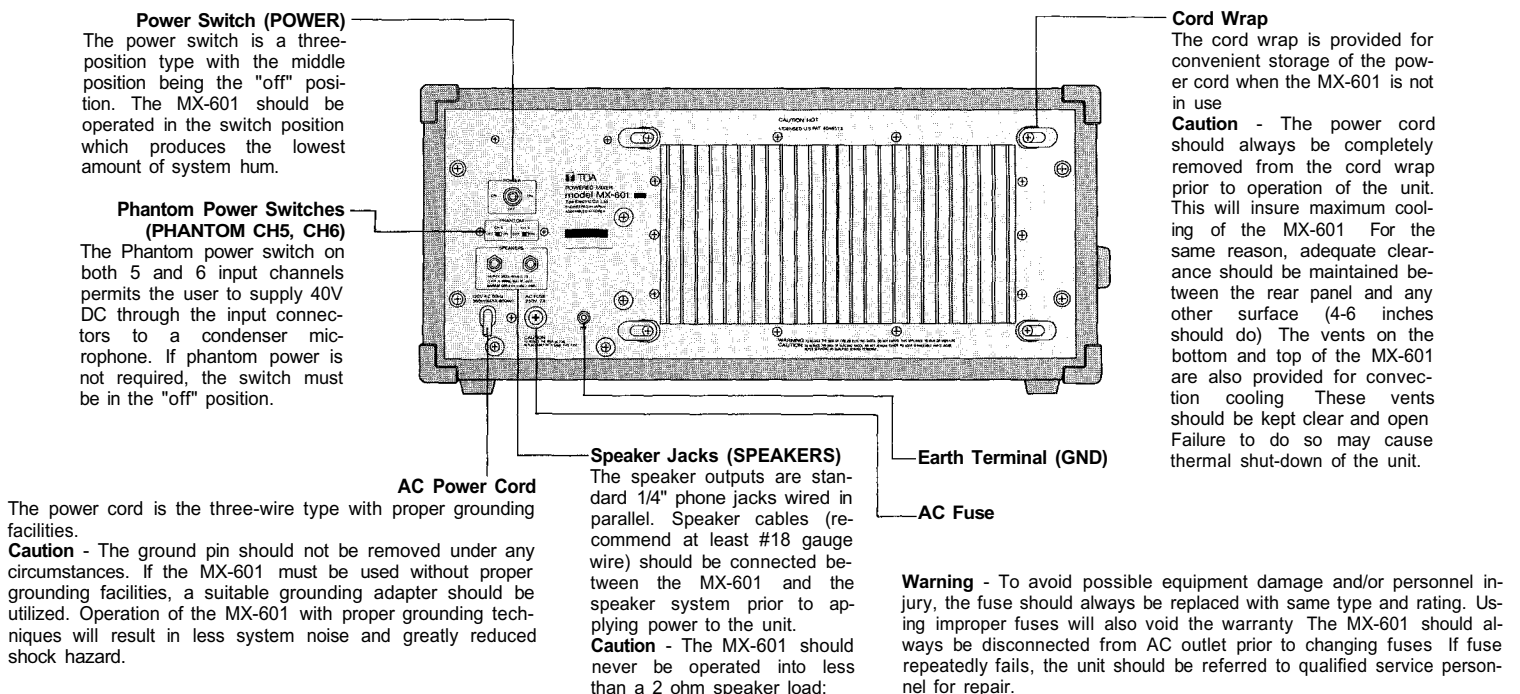

● Connection Examples

Low Z input should be connected with low impedance (50 ohm ~ 600 ohm) microphone

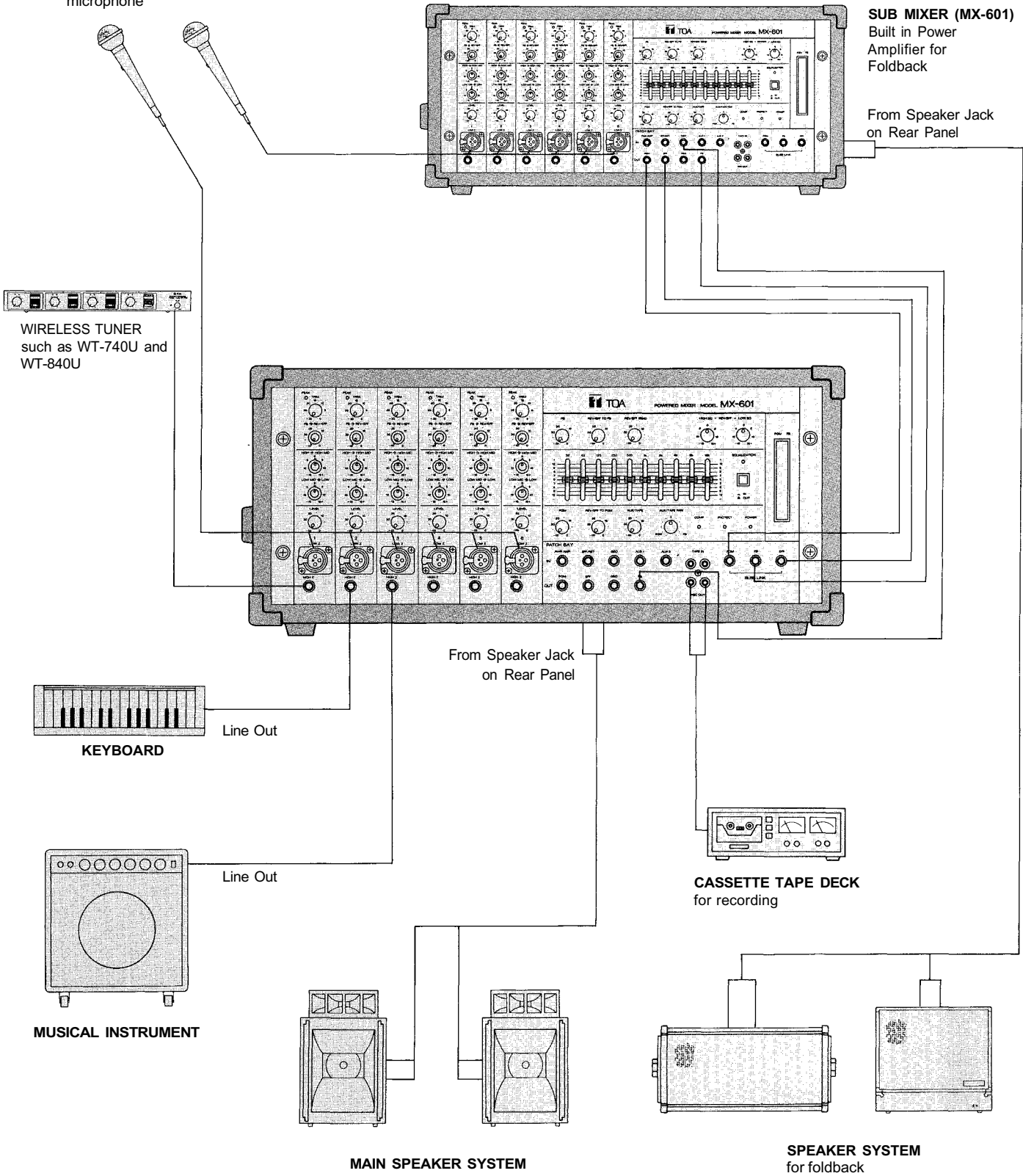

● Input Connections

Generally speaking, there are two rules to follow when connecting equipment outputs to the inputs of other equipment.

1. Properly match the impedances of the outputs and inputs.
2. Connect low impedance outputs to high impedance inputs.

It goes without saying that not only input and output impedance matching but also level matching should be taken into consideration. Each input channel of the MX-601 is provided with an input TRIM control, so the usable signal level range is very wide. Input impedances and levels are shown in the following table.

INPUT SPECIFICATIONS

CONNECTION	INPUT	ACTUAL LOAD IMPEDANCE	FOR USE WITH NOMINAL	TRIM POSITION	SENSITIVITY (PGM OUTPUT LEVEL +4dB)	MAX BEFORE CLIP INPUT LEVEL	CONNECTOR
CH1 }	LOW Z	OPEN	50Ω to 250Ω MICRO-PHONES	0	-55dBm (1.38mV)	-34dBm (15mV)	XLR TYPE NC3F
				-30	-16dBm (123mV)	+ 1.7dB (0.94V)	
CH6	HIGH Z	50kΩ	50kΩ OR LOWER IMP LINES	0	-35dBm (13.8mV)	-14dBm (150mV)	PHONE JACK
				-30	+4dBm (1.23V)	+20dB (7.75V)	
AUX (1~2)		10kΩ	10kΩ OR LOWER IMP, LINES		-20dBm (77.5mV)	-2dBm (0.61V)	PHONE JACK
EFF/RET		50kΩ	50kΩ OR LOWER IMP, LINES		-20dBm (77.5mV)	-2dBm (0.61V)	PHONE JACK
GEQ		50kΩ	50kΩ OR LOWER IMP, LINES		+4dBm (1.23V)		PHONE JACK
PWR/AMP		10kΩ	10kΩ OR LOWER IMP		+4dBm (1.23V)		PHONE JACK
TAPE		10kΩ	10kΩ OR LOWER IMP, LINES		-20dBm (77.5mV)	-2dBm (0.61V)	PCA PIN JACK

*Sensitivity is the level required to produce a program out level of +4dBm.

*0dBm is referenced to 0.775V RMS.

All XLR Type connectors are electronic balanced. Phone jack is unbalanced.

If the line going from one piece of equipment to another is long (more than 5m), we recommend that balanced outputs be connected to balanced inputs.

As is described in the beginning of the Operating Instructions Manual, the connectors of the MX-601 are wired as follows: Pin 1 is ground (shield). Pin 2 is cold (low, minus). Pin 3 is hot (high, plus).

● How to get a good mix

Before connecting other equipment to Powered mixer, check the impedance and level of both. If the impedances and levels do not match, mixing will be very difficult and the S/N ratio will also be adversely affected.

Each input channel of the MX-601 is provided with a TRIM control. Thorough understanding of the function of a TRIM control will make mixing easier.

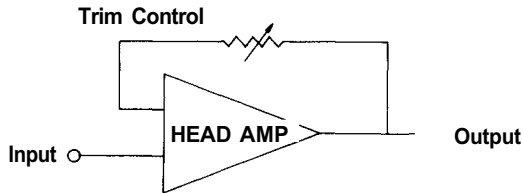

The function of the TRIM control is to control the negative feedback volume of the head-amp so that the gain of the head-amp can also be changed. Because of this, enough dynamic range, even for high level signals is ensured. Also, the S/N ratio will be better by decreasing the gain of the head-amp.

For example, a keyboard, a musical instrument and a dynamic microphone with output levels of -10dBm, -20dBm and -40dBm respectively are connected to the MX-601.

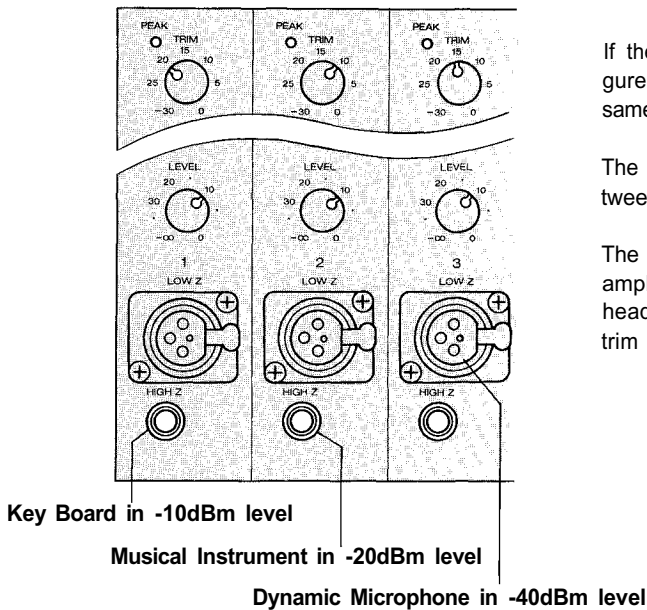

If the trim control is set as shown in the left figure, the input level controls can be set to the same position.

The input level controls are used in general between -5 and -15.

The peak indicator LED illuminates if the head amplifier or equalizer is clipping. The gain of the head-amplifier must be decreased by turning the trim control counterclockwise.

Fault Protection Table

Fault	Protection	Indication	Action	Restoration
Excessive current due to overloads	Current limiter activates at less than 1 ohm.	Compressor LED illuminates	Remove excessive loads. Minimum speaker loads 2 ohms	Automatic restoration after normal loads are obtained
Short circuits (less than 0.4-ohm)	Current limiter activates, input signal is lowered, unit shuts down.	Amp protection LED illuminates	Check speaker lines/ systems for shorts	Turn off power switch Turn on into operational loads.
Temperature rise of heat sink (more than 105°C)	Input signal is lowered Unit shuts down	Amp protection LED illuminates.	Check for adequate ventilation.	Automatic restoration after temperature lowers (to 75°C - 95°C)
DC drift	Input signal is lowered Unit shuts down.	Amp protection LED illuminates	Refer to qualified service personnel.	Automatic restoration after normal bias is regained

Block and Level Diagrams

BLOCK DIAGRAMS

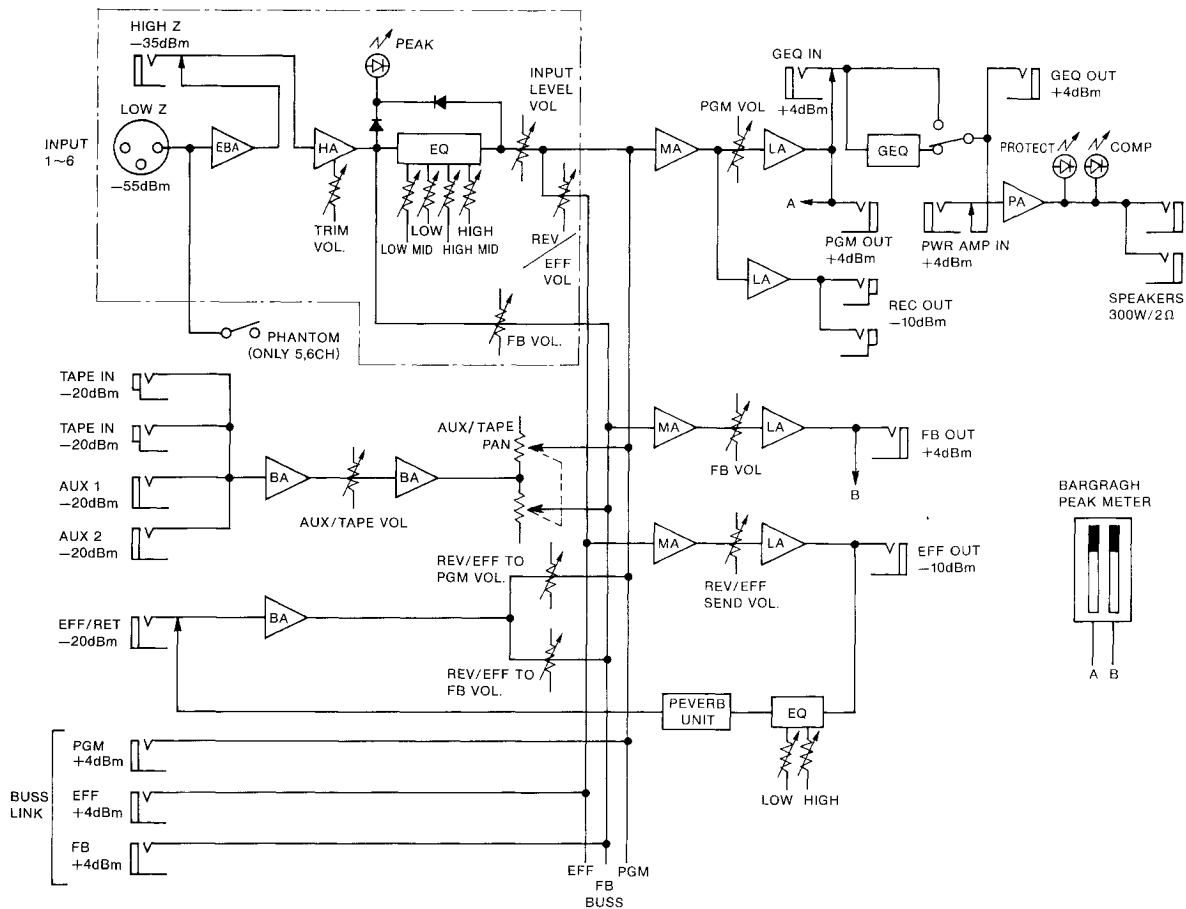

LEVEL DIAGRAM

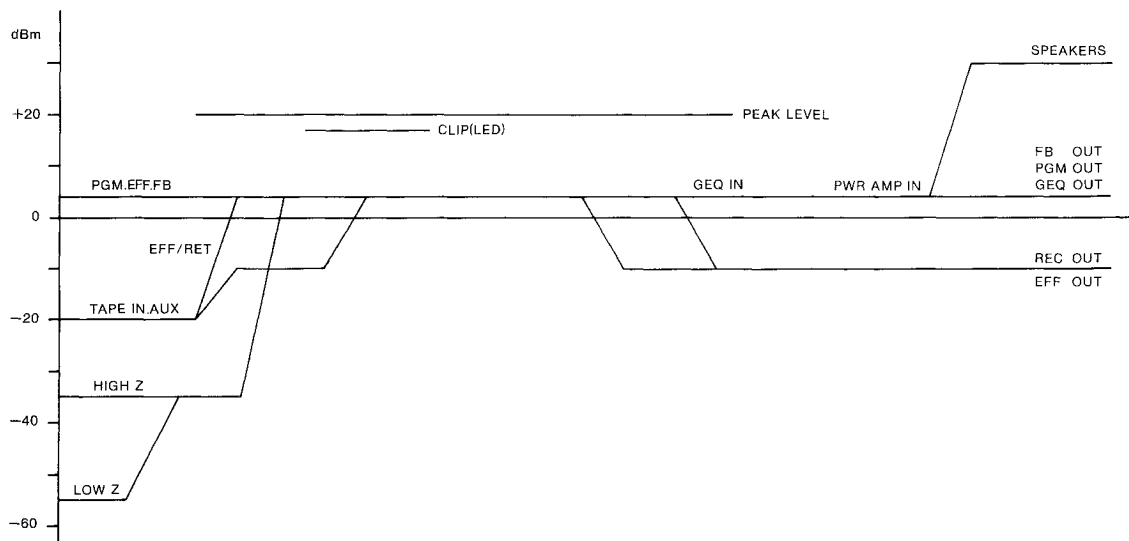

Specifications

MIXER SECTION

Frequency Response

+0, -3dB 30Hz~20kHz (HIGH Zinput TRIM at "-30" position.)

Total Harmonic Distortion

0.05% +4dBm at 1kHz.

Hum and Noise (Open)

Equivalent Input Noise -130dBm (20Hz~20kHz)
 Equivalent Input Noise -133dBm (IHF A)
 All level Controls Minimum -102dBm (IHF A)
 PGM Master at MAX and all input level controls minimum -93dBm (IHF A)
 PGM Master at MAX and one input level control at MAX -72dBm (IHF A)

Maximum Voltage Gain

INPUT to PGM out 59dB
 INPUT to EFF out 45dB

INPUT to FB out 59dB
 INPUT to REC out 45dB
 INPUT to GEQ out 59dB
 AUX to PGM out 24dB
 TAPE to PGM out 24dB
 EFF/RET to PGM out 24dB

Equalization

32Hz±12dB Peaking 1kHz±12dB Peaking
 63Hz±12dB Peaking 2kHz±12dB Peaking
 125Hz±12dB Peaking 4kHz±12dB Peaking
 250kHz±12dB Peaking 8kHz±12dB Peaking
 500Hz±12dB Peaking 16kHz±12dB Peaking

Peak Indicators

Red LED on each input channel LED's turn on at 3dB below clipping.

INPUT SPECIFICATIONS

CONNECTION	INPUT	ACTURAL LOAD IMPEDANCE	FOR USE WITH NOMINAL	TRIM POSITION	SENSITIVITY (PGM OUTPUT LEVEL +4dB)	MAX BEFORE CLIP INPUT LEVEL	CONNECTOR
CH1 }	LOW Z	OPEN	50Ω TO 250Ω MICRO-PHONES	0	-55dBm (1.38mV)	-34dBm (15mV)	XLR TYPE NC3F
				-30	-16dBm (123mV)	+17dB (0.94V)	
CH6	HIGH Z	50kΩ	50kΩ OR LOWER IMP LINES	0	-35dBm (13.8mV)	-14dBm (150mV)	PHONE JACK
				-30	+4dBm (1.23V)	+20dB (7.75V)	
AUX (1~2)	—	10kΩ	10kΩ OR LOWER IMP. LINES	—	-20dBm (77.5mV)	-2dBm (0.61V)	PHONE JACK
EFF/RET	—	50kΩ	50kΩ OR LOWER IMP. LINES	—	-20dBm (77.5mV)	-2dBm (0.61V)	PHONE JACK
GEQ	—	50kΩ	50kΩ OR LOWER IMP. LINES	—	+4dBm (1.23V)	—	PHONE JACK
PWR/AMP	—	10kΩ	10kΩ OR LOWER IMP	—	+4dBm (1.23V)	—	PHONE JACK
TAPE	—	10kΩ	10kΩ OR LOWER IMP. LINES	—	-20dBm (77.5mV)	-2dBm (0.61V)	PCA PIN JACK

OUTPUT SPECIFICATIONS

CONNECTION	ACTUAL LOAD IMPEDANCE	FOR USE WITH NOMINAL	OUTPUT LEVEL		CONNECTOR
			NOMINAL	MAX. BEFORE CLIP	
PGM	600Ω	600Ω OR HIGHER IMP. LINES	+4dB (1.23V)	+20dB (7.75V)	PHONE JACK
EFF	600Ω	600Ω OR HIGHER IMP. LINES	-10dB (245mV)	+8dB (1.9V)	PHONE JACK
GEQ	600Ω	600Ω OR HIGHER IMP. LINES	+4dB (1.23V)	+20dB (7.75V)	PHONE JACK
FB	600Ω	600Ω OR HIGHER IMP. LINES	+4dB (1.23V)	+20dB (7.75V)	PHONE JACK
REC	1kΩ	1kΩ OR HIGHER IMP. LINES	-10dB (245mV)	+8dB (1.9V)	RCA PIN JACK

POWER AMPLIFIER SECTION

Frequency Response

+0, -1dB 5Hz to 40kHz (200W RMS 4Ω)

Rated Power & Load

300W RMS (2Ω) 200W RMS (4Ω) 120W RMS (8Ω)

Power Output at Clipping

1% THD, 1kHz

348W RMS (2Ω) 238W RMS (4Ω) 140W RMS (8Ω)

Total Harmonic Distortion

Less than 0.1% (200mW~200W RMS, 20Hz~20kHz)

Typically below 0.05%

Compressor Dynamic Range

Greater than 26dB

Hum and Noise

At least 110dB S/N ratio, 20Hz~20kHz

At least 113dB S/N ratio IHF-A weighted

Damping Factor

Greater than 200 (1kHz 4Ω)

Input Sensitivity

+4dBm (1.23V)

Input Impedance

10kΩ

Output Connector

Phone Jack x2

Dimensions

588(W)x265(H)x302(D) (23.15x10.43x11.89) inch.

Weight

18.5kg (40.79 lbs)

*0dBm is referenced to 0.775V RMS.

*Specifications are subject to change without notice.

Characteristic Diagrams

HIGH Z IN. TRIM/MIN. & INPUT EQ

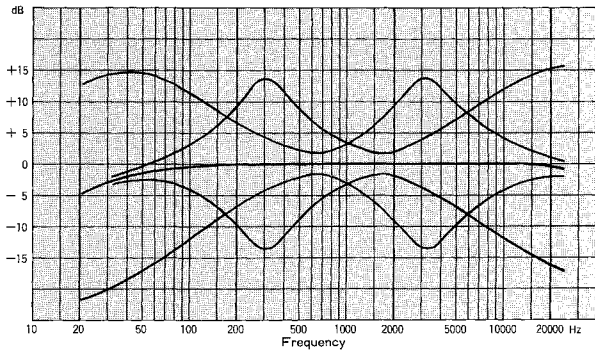

GEQ

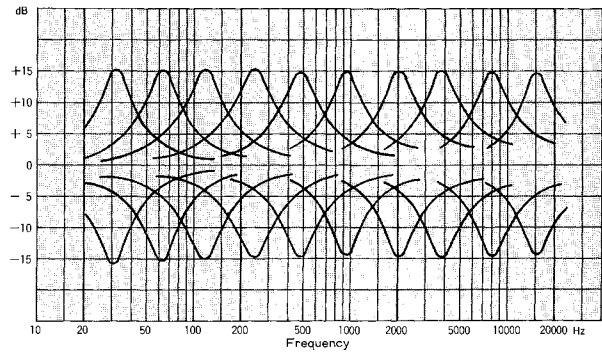

POWER AMP POWER BAND WIDTH

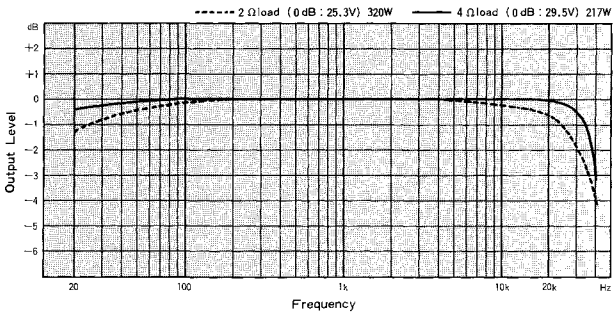

POWER AMP TOTAL HARMONIC DISTORTION

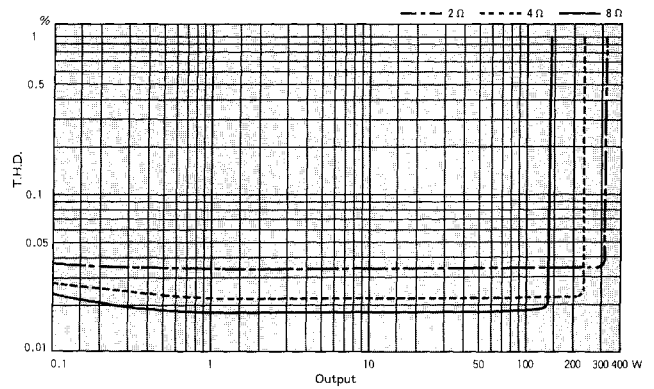

POWER AMP COMPRESSOR

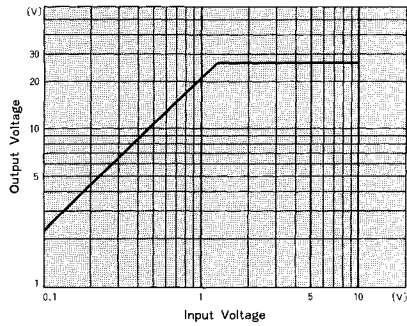

REVERBERATION FREQUENCY RESPONSE

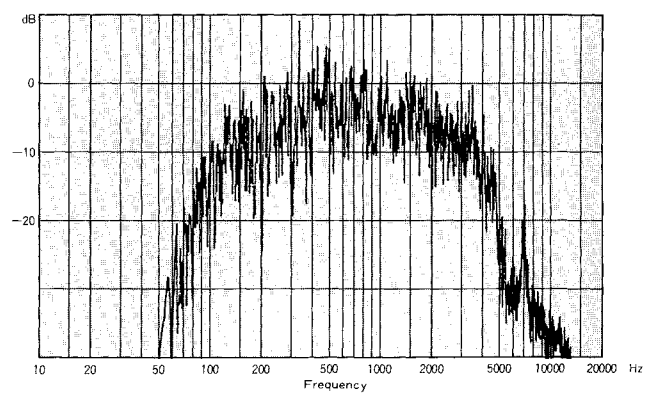

Appearance

