

TOA Electronics, Inc.

DP-0206 DIGITAL SIGNAL PROCESSOR



DACsys 2000

THE DP-0206 DIGITAL SIGNAL PROCESSOR is TOA's third generation of industrial-grade, high-quality digital signal processors. Beginning in 1988 with the groundbreaking introduction of Saori, followed by the popular DACsys II Series in 1994, TOA was the first manufacturer to introduce the benefits of DSP to the professional audio community. Already recognized for superior sound quality and unmatched reliability, TOA continues to improve and refine the application of DSP for sound systems with the new DP-0206's *CLEAR Conversion* analog-to-digital technology (Pat. Pending). The DP-0206 is an ideal, cost-effective solution for small and large-scale permanent installation applications including auditoriums, convention centers, educational facilities, houses of worship, performing arts centers, sports facilities and theaters.



- **Digital Signal Processor** for permanent sound system installations.
- **Modular Design** — 2-Input/6-Output (2x6), easily expandable to 2x8, 2x10, 4x6, 4x8, or 6x6 using optional analog or digital I/O modules.
- **Unmatched TOA Quality and Reliability**, successor to the popular DACsys II Series
- **Superior Sound Quality** — 110 dB Dynamic Range
- **TOA CLEAR Conversion Technology (Pat. Pending)** with precise 24-bit analog-to-digital conversion.
- **Essential Audio Processing Tools** — Compressors, Peak Limiters, Noise Gates, Crossovers, Multi-Band Filtering, Parametric and Graphic EQ, High/Low-Pass, All-Pass and Notch Filters, Horn EQ, High/Low Shelving, Driver Alignment and Output Delays.
- **Built-In Matrix/Router** allows any combination of input-to-output signal routing for zoning or room-combining applications.
- **16 On-Board Memories** for storage and recall of different signal routing and parameter configurations.
- **Intuitive Control Software** for simultaneous programming and control of up to 30 DP-0206 units via RS-232 or RS-485 serial communication.
- **Measurement Data Import Function** allows crossover and equalization tuning of measured speaker system response files exported from SIA Smart and Goldline TEF software.
- **Flexible Remote Control** with simple dry contact-closure activation of Memory Recall, Output Volume Control and Output Muting via programmable control module (optional).
- **Control Protocol Available** for interfacing with remote control devices such as Crestron or Panja/AMX.
- **Effortless Connection From Computer to Unit** with automatic Com port, baud rate and Unit ID detection.
- **Comprehensive Security Features (hardware and software)** for front panel lock and password-protecting system settings.
- **Five Year Warranty**

HIGHLIGHTS

THE UNIQUE, MODULAR DESIGN OF THE DP-0206 allows system designers to specify the most cost-effective configuration for each project. The standard 2-input and 6-output (2x6) configuration is easily expandable to five additional configurations—2x8, 2x10, 4x6, 4x8 and 6x6—via optional analog or digital I/O modules. The DP-0206 combines all the essential audio signal processing functions typically found between mixers and power amplifiers—dynamics control, equalization, crossovers, delays and signal routing—into a single compact and powerful unit. The DP-0206 can be used for loudspeaker management, post-mix processing, room-combining, stereo two, three and four-way crossover with mono sum for subwoofers, driver and cluster alignment, full-range zoning, signal routing, surround sound or any other application requiring precise audio processing tools. Advanced users will especially appreciate the wide variety and quantity of multi-band filtering including parametric, all-pass, notch, high/low pass/shelving, CD horn EQ—any combination of twelve filters on each input and each output.

All processing configurations and parameters for up to thirty DP-0206 units are set with a PC and the intuitive new DACsys 2000 control software. You can configure systems off-line at the office, upload to the unit(s) at the job-site, then disconnect the PC and recall different signal flow and parameter settings from sixteen on-board memories. An innovative and time-saving measurement data import function allows audio professionals to tune crossovers and equalize measured speaker system response files exported from SIA Smaart and Goldline TEF software. Comprehensive hardware and software security features such as front panel lock and multi-level password access protect system settings. An optional remote control module allows simple contact-closure activation of memory recall, output volume control and output muting.

The DP-0206 is backed with a five-year warranty.

TOA CLEAR CONVERSION TECHNOLOGY

Those familiar with DSP will agree that the method of converting the analog input signal to the digital domain (A/D conversion) is one of the keys to producing great sound. TOA's newly developed *CLEAR** Conversion technology

routes low level input signals below a specific threshold through a separate gain stage and a second, separate A/D path. This minimizes unwanted noise (quantization error) produced using conventional, single A/D conversion methods. TOA's *CLEAR Conversion* (Pat. Pending) features ultra-smooth cross-fade switching between the two A/D signal paths resulting in greater than 110 dB dynamic range, significantly lower noise and most importantly – clear, transparent, natural-sounding audio.

*Cross-Linked Exact A/D Resolution

DACsys 2000 PRODUCTS

DP-0206	Modular Digital Signal Processor (2-Input / 6-Output)
DQ-A01	Dual Analog Input Module *
DQ-A02	Dual Analog Output Module *
DQ-D01	Dual Digital (AES/EBU) Input/Output Module (switch-selectable) *
DQ-C01	Remote Control Module (Memory/Volume/Mute)

*Two I/O expansion slots allow any combination of analog or digital I/O modules.

CONFIGURATIONS

- Post-Mix Processing
- Stereo Two, Three and Four-Way with Mono Sum for Subwoofers
- Driver and Cluster Alignment
- Full-Range Zoning
- Loudspeaker Processor
- Monitor Processor
- Room Combining
- Signal Routing
- Surround Sound - L-C-R + Sub and Rear Channels

APPLICATIONS

- Auditoriums
- Conference Facilities
- Convention Centers
- Educational Facilities
- Gymnasiums
- Hotels
- Houses of Worship
- Performing Arts Centers
- Sports Facilities
- Theaters
- Theme Parks

Front Panel View

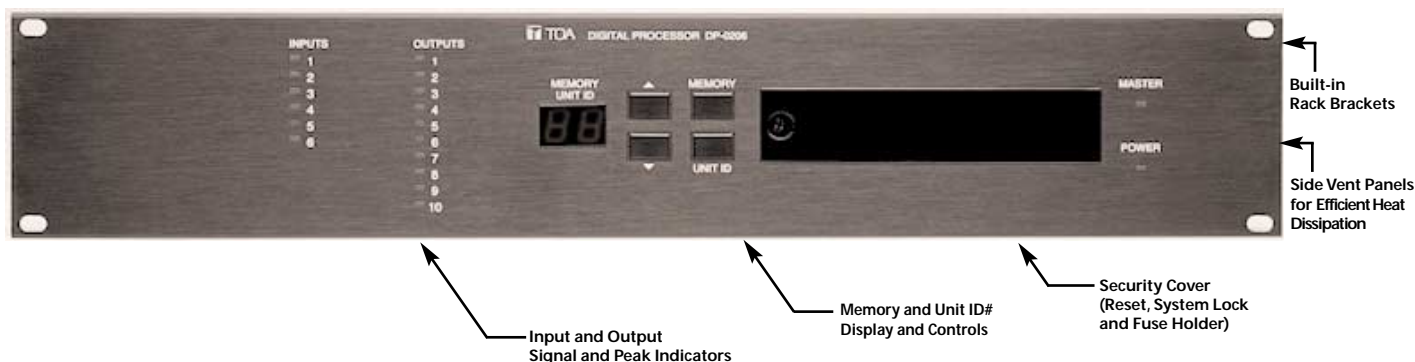

Rear Panel View

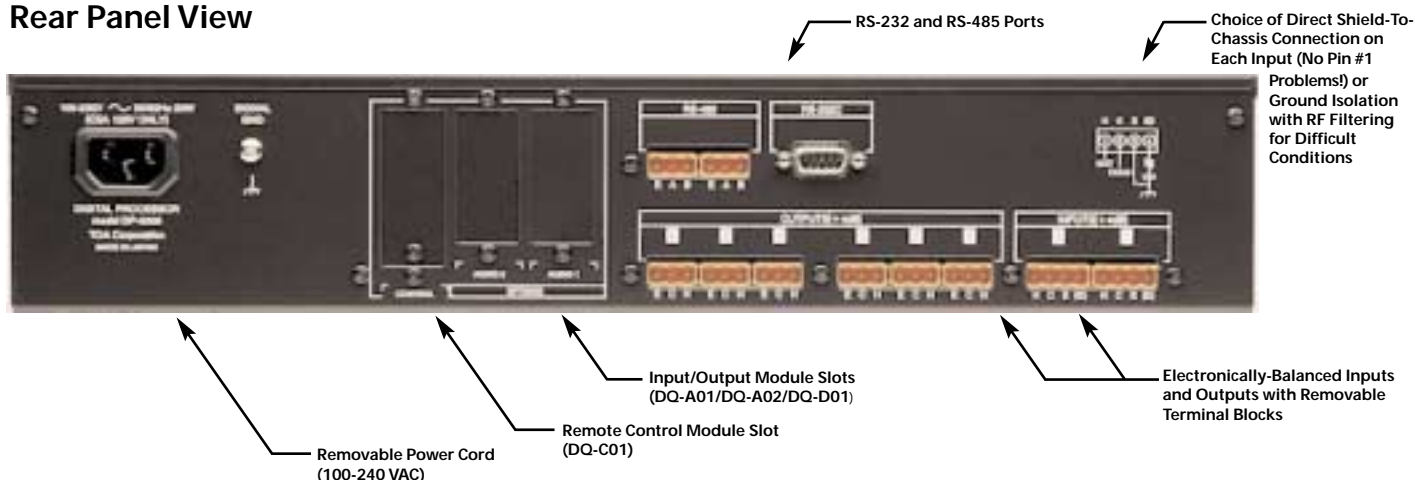

Expandable Inputs & Outputs

Using optional modules, the 2-input/6-output DP-0206 can be easily expanded allowing you to specify the correct number of inputs and outputs for each application.

Inputs	Outputs	DQ-A01 Dual Analog Input Module*	DQ-A02 Dual Analog Output Module*
2	6	—	—
2	8	—	1
2	10	—	2
4	6	1	—
4	8	1	1
6	6	2	—

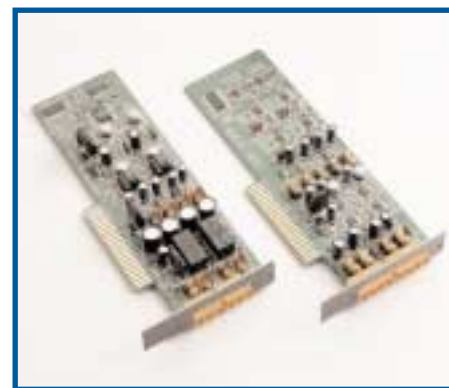

*Substitute the DQ-D01 Dual Digital Input/Output Module (AES/EBU) for the DQ-A01 or the DQ-A02 to provide two digital input channels or two digital output channels (switch-selectable).

DACSYS 2000 SOFTWARE

FEATURES

- Intuitive Project View allows access to all processing functions, signal flow and memories of up to 30 DP-0206 units.
- Unit Configuration Wizard for fast, easy setup and configuration.
- Store and Recall Unit Templates
- Flexible Naming— Memories, I/O and Units
- Group Processing Blocks within or between Units
- Cut, Copy and Paste within or between Units and Processing Blocks.
- Undo/Redo
- Memory Compare
- Save/Archive to Disk for backup or future installations.
- Print Settings for client at job completion.
- Export to Microsoft Excel for custom data manipulation.
- Password-Protect individual processing blocks, configurations and memories

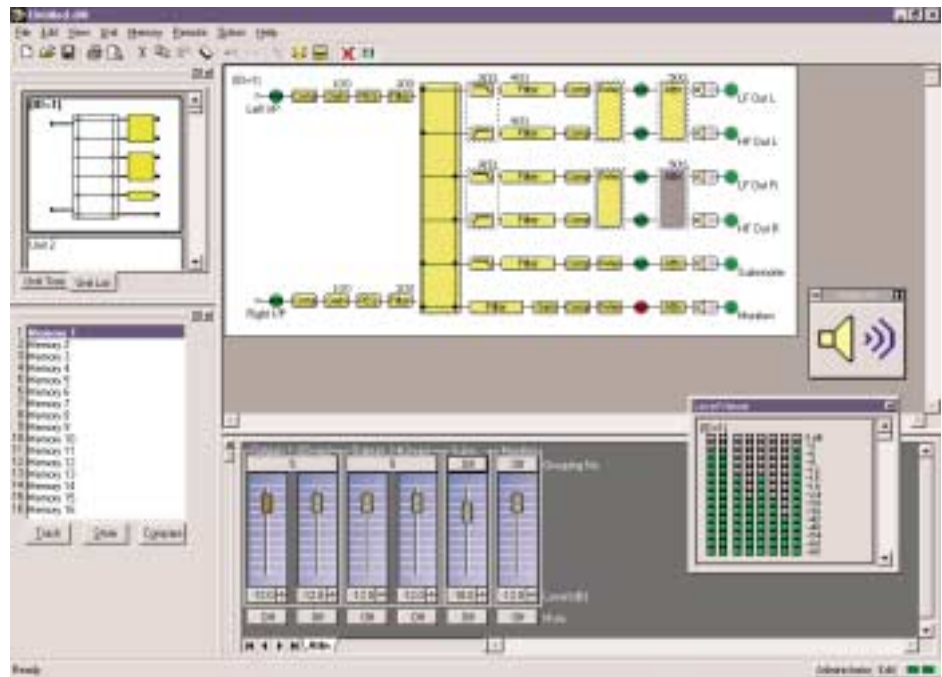

PROGRAMMABLE REMOTE CONTROL MODULE (DQ-C01)

- Simple Switch Activation (dry-contact)
- Eight Control Terminals, Assignable via Software to:
 - Memory Change
 - Output Volume
 - Output Muting

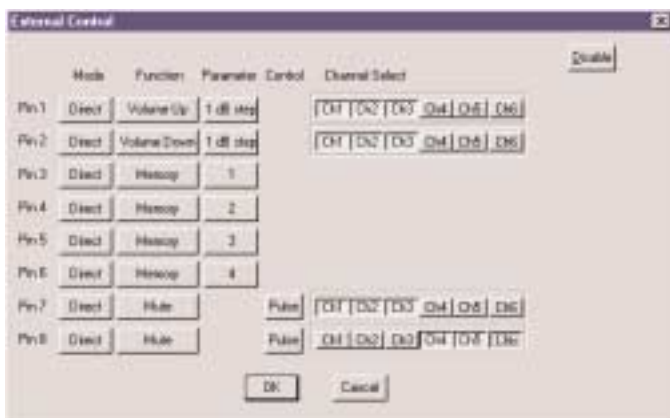

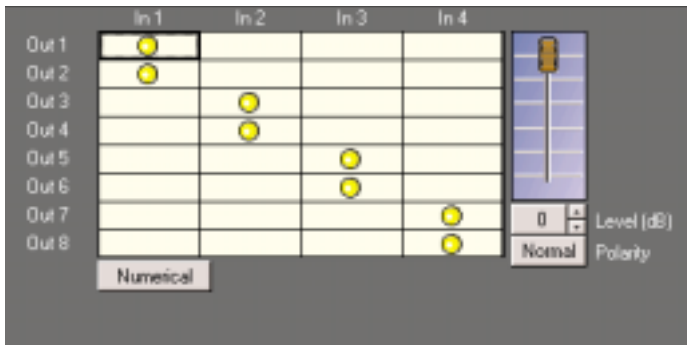

MATRIX/ROUTER

- Any Combination of Input-to-Output Signal Routing
- Store a Different Configuration in Each of Sixteen Memories
- Individual Level Control and Polarity Inversion on Each Crosspoint
- Graphic or Numeric Parameter Entry
- Graphic or Table Display

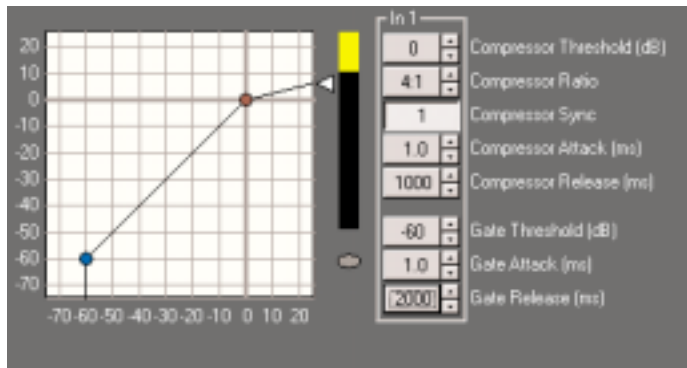

DYNAMICS CONTROL

- Compressor/Limiter and Noise-Gate on Each Input and Output
- Real-Time Metering of Compression and Gate Activation
- Control Multiple Inputs or Outputs from One Window
- Controls:
 - Compressor: Threshold, Ratio, Attack, Release and Sync
 - Gate: Threshold, Attack and Release
- Graphic or Numeric Parameter Entry

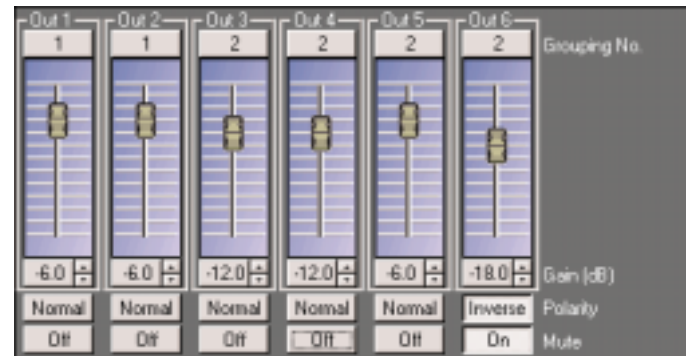

LEVEL CONTROL

- Control All Input or Output Levels from a Single Window
- Polarity Inversion on Each Input/Output
- Multiple Input/Output Grouping with Relative Offset
- Post D/A Analog Output Attenuators ensure optimum digital-to-analog conversion.
- Graphic or Numeric Parameter Entry
- Individual or All Output Muting

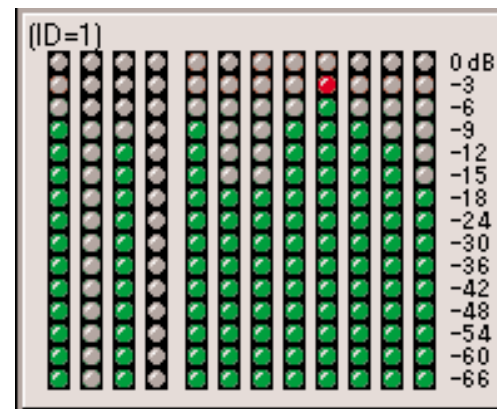

LEVEL MONITOR VIEW

- Input and Output Channel Metering
- Signal and Clip Indication

SIGNAL PROCESSING FEATURES

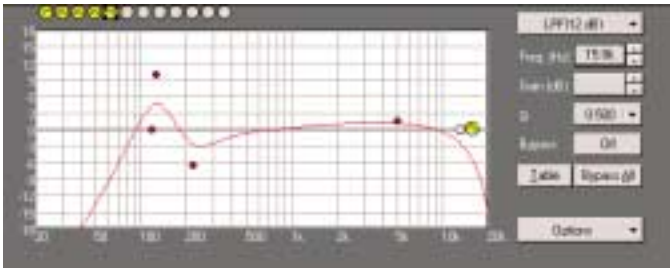

FILTER / EQUALIZATION

- 12 Filters on Each Input and Output
- Filter Types:
 - Parametric
 - Graphic
 - High and Low-Pass
 - High and Low-Shelving
 - All-Pass
 - Notch
 - Constant Directivity Horn EQ
- Graphic or Numeric Parameter Entry with Fine or Coarse Increments
- Filter Bandwidth (Q) Display In Numeric or Fractional Octaves
- Bypass All or Individual Filters
- Graphic or Table Display

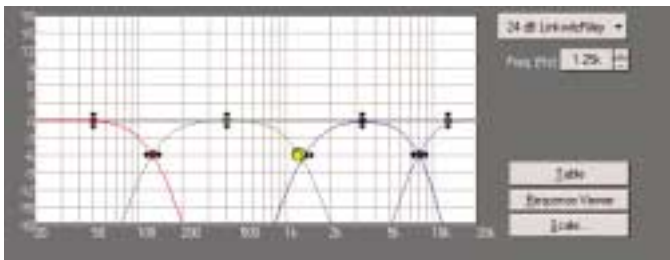

CROSSOVER/CHANNEL DIVIDER

- Crossover Types:
 - Bessel (-12, -18 and -24 dB/octave)
 - Butterworth (-12, -18 and -24 dB/octave)
 - Linkwitz-Riley (-12 and -24 dB/octave)
 - Variable-Q — allows custom crossover slopes
- Symmetrical or Asymmetrical Crossover Slopes
- Polarity Inversion
- Save Crossover Templates to create a library of reusable speaker systems for future installations.

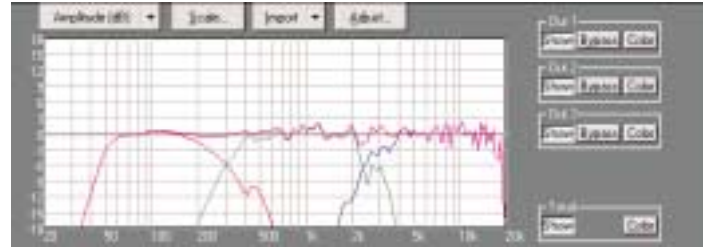

OUTPUT RESPONSE VIEWER WITH MEASUREMENT DATA IMPORT

- Amplitude, Phase and Group Delay of individual outputs plus the combined (summed) output response.
- Import Measured Smart or TEF Data for off-line crossover tuning, alignment and equalization.
- Frequency/Level/Phase/Delay Locator
- Adjustable Graph Scaling
- Flexible Color Assignments

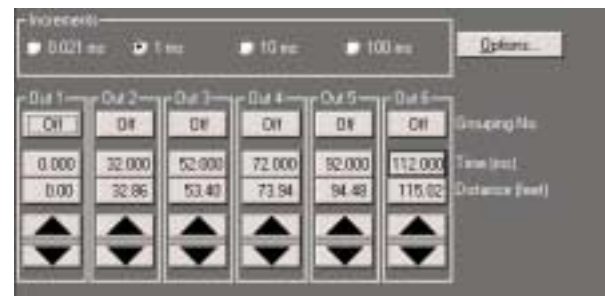

Out 1	Out 2	Out 3	Out 4	Out 5	Out 6	Grouping (ms)
0.000	32.000	52.000	72.000	92.000	112.000	
0.00	32.86	53.40	73.94	94.48	115.02	

DRIVER ALIGNMENT AND OUTPUT DELAY

- Individual Delay (683 ms) on Each Output Channel
- Additional Driver Alignment Delay (683 ms) on Each Crossover Channel
- Numerical Entry with Fine or Coarse Increments.
- Direct Entry and Display of Distance (inches, feet or meters)
- Multiple Delay Grouping with Relative Offset
- Temperature Calibration (°C or °F)

DP-0206 HARDWARE

Power Source	100 - 240 VAC, 50/60 Hz	Memories	16 (different configuration in each possible), FLASH storage
Power Consumption	30 W	Programming and Control	<p>Control Software:</p> <ul style="list-style-type: none"> ■ PC software (Windows 95/98/Me/NT/2000** compatible) <p>Communication Method:</p> <ul style="list-style-type: none"> ■ RS-232C: individual unit, front and rear panel D-sub connector (9-pin), standard "through-type" serial cable ■ RS-485: up to 30 units, 2x removable terminal block, 3 poles <p>Optional Remote Control Module (DQ-C01):</p> <ul style="list-style-type: none"> ■ Programmable Memory Selection, Output Volume Control and Output Muting via Contact Closure Activation
Frequency Response	20 – 20,000 Hz (±1 dB)	Security Functions	<p>Hardware:</p> <ul style="list-style-type: none"> ■ Front Panel System Lock <p>Software:</p> <ul style="list-style-type: none"> ■ Multiple User-Level Password-Restricted Access
Dynamic Range <i>(A-weighted)</i>	110 dB	Front Panel Control	Memory Recall, Unit ID, Up/Down
Total Harmonic Distortion	Less than 0.05% <i>(1 kHz, +4 dBu*, 20 Hz - 20 kHz, BPF)</i>	Front Panel Indicators	<p>Input/Output Level: Green (-48 to +18 dBu)</p> <p>Input/Output Peak: Red (greater than +18 dBu)</p> <p>Memory No./Unit ID, Master</p>
Inputs	<ul style="list-style-type: none"> ■ Two (expandable to up to six, depending on number of outputs) ■ Electronically-balanced, +4 dBu* (Max. +24 dBu*), 10 kΩ ■ Connector: removable terminal block, 4 poles ■ Two Shield Connection Points: Direct-to-chassis and RFI filter-to-chassis 	Finish	<p>Front Panel: Aluminum, hair-line finish, black</p> <p>Other: Pre-coated steel plate, black, 30% gloss</p>
Outputs	<ul style="list-style-type: none"> ■ Six (expandable to up to ten, depending on number of inputs) ■ Electronically-balanced, +4 dBu* (Max. +24 dBu*), 600 Ω minimum load impedance ■ Connector: removable terminal block, 3 poles 	Dimensions <i>(W x H x D)</i>	19" x 3.5" x 12.8" (480 mm x 88.4 mm x 325.2 mm)
I/O Configurations	2x6 (default) <i>Expandable to:</i> 2x8 2x10 4x6 4x8 6x6	Weight	10.3 lbs. (4.65 kg)
I/O Module Slots	Two, for optional I/O Modules, DQ-A01, DQ-A02, DQ-D01	Accessories <i>(included)</i>	Rack-Mount Screw x 4 (metric), Fuse x 1, Power cord x 1
Control Module Slot	One, for optional Control Module, DQ-C01	Options	<p>DQ-A01: Dual Input Module (Analog)</p> <p>DQ-A02: Dual Output Module (Analog)</p> <p>DQ-D01: Dual Digital (AES/EBU) I/O Module</p> <p>DQ-C01: Remote Control Module (Memory, Output Volume, Output Mute)</p>
Sampling Frequency	48 kHz	Propagation Delay	Less than 1.4 ms
A/D and D/A Conversion	24 bit	Firmware	FLASH storage, upgradeable via software utility
Internal DSP	3 x Motorola 56364, 24 bit, 100 MIPS, 100 MHz		

*0 dB = 0.775 V

**Windows 95/98/Me/NT/2000 are registered trademarks of Microsoft Corporation.

DQ-A01 DUAL ANALOG INPUT MODULE DQ-A02 DUAL ANALOG OUTPUT MODULE

Input/Output

DQ-A01:

- Two input channels
- Electronically-balanced, +4 dBu* (Max. +24 dBu*), 10 k Ω
- Connector: removable terminal block, 4 poles
- Two Shield Connection Points: Direct-to-chassis and RFI filter-to-chassis

DQ-A02:

- Two output channels
- Electronically-balanced, +4 dBu* (Max. +24 dBu*), 600 Ω minimum load
- Connector: Removable terminal block, 3 poles

A/D and D/A Conversion	24 bit
Sampling Frequency	48 kHz
Frequency Response	20 – 20,000 Hz (± 1 dB)
Dynamic Range <i>(A-weighted)</i>	110 dB
Total Harmonic Distortion <i>(1 kHz, +4 dBu*, 20 Hz - 20 kHz, BPF)</i>	Less than 0.05%
Finish	Pre-coated steel plate, black, 30% glossy
Dimensions <i>(W x H x D)</i>	1.0" x 3.0" x 6.6" (25.6 mm x 76.5 mm x 168 mm)
Weight	<i>DQ-A01:</i> 0.18 lbs. (80 g) <i>DQ-A02:</i> 0.22 lbs. (100 g)
Accessories	Mounting screw x 2, Seal x 2, Removable terminal block x 2

DQ-D01 DUAL DIGITAL INPUT/OUTPUT MODULE

Input/Output

- Switch-selectable I/O, configurable as two input channels or two output channels.
- Connector: BNC-F

Digital Transmission Format	AES/EBU
Finish	Pre-coated steel plate, black, 30% glossy
Dimensions <i>(W x H x D)</i>	1.0" x 3.0" x 6.0" (25.6 mm x 76.5 mm x 152 mm)
Weight	0.18 lbs. (80 g)
Accessories	Mounting screw x 2, Seal x 2

DQ-C01 REMOTE CONTROL MODULE

Control Inputs

- Terminals 1–8, Common
- Dry contact closure activation
- Open circuit voltage: 5 VDC, short circuit current: 25 mA
- Connector: Removable terminal block (9 poles)

Memory Selection

- Direct: 8 memories (One terminal each)
- Binary: 16 memories (Four terminals)

Control Method:

- Direct/Binary: No-voltage make of over 500 ms
- Binary: No-voltage make pulse of over 500 ms

Volume Control (Up/Down)

- Direct: Max. 4 groups of output channels (Two terminals per group)
- Binary: Max. 10 groups of output channels (Any output channel or channel group can be assigned to each terminal.)

Control Method:

- 1-step variation with no-voltage make pulse of over 500 ms.
- Continuous variation in 500 ms units with pulse of over 700 ms.
- Continuous up/down variation in 500 ms units with the addition of no-voltage make pulse of over 700 ms.
- Continuous volume variation stops after break pulse.

Variable Range:

- +12 to $-\infty$ dB

Muting (On/Off)

- Max. 8 groups (Any output channel or channel group can be assigned to each terminal.)

Control method:

- No-voltage make of over 500 ms/No-voltage make pulse of over 500 ms.

Configuration Setting

PC software

*(Windows 95/98/Me/NT/2000 compatible)***

Finish	Pre-coated steel plate, black, 30% glossy
Dimensions <i>(W x H x D)</i>	1.0" x 3.0" x 4.0" (25.6 mm x 76.5 mm x 101 mm)
Weight	0.13 lbs. (60 g)
Accessories	Mounting screw x 2, Removable terminal block x 1

*0 dB = 0.775 V

**Windows 95/98/Me/NT/2000 are registered trademarks of Microsoft Corporation.

SIGNAL PROCESSING

Matrix/Router

- Any Combination of Input-to-Output Signal Routing
- Individual Crosspoint
 - Routing On/Off
 - Level Control (0 to $-\infty$ dB)
 - Polarity Invert/Normal

Level Control/Gain

- +12 to $-\infty$ dB
- Polarity Invert/Normal
- Mute

Dynamics

Compressor:

- Threshold: -16 to $+24$ dBu*
- Ratio: 1 : 1 to ∞ : 1
- Attack time: 0.02 – 100 ms
- Release time: 10 ms – 5 s
- Synch: On/Off

Gate:

- Threshold: $-\infty$ to -26 dBu*
- Attack time: 0.1 – 100 ms,
- Release Time: 20 ms – 5 s

Equalization /Filters

Inputs (pre-matrix/router):

- 12 filters each, any combination of filter types.

Outputs (post-matrix/router):

- 12 filters each (w/o crossover), any combination of filter types.

All-Pass Filter:

- 20 – 20,000 Hz
- Q: 0.267 – 69.249 (4 to 1/48th octave)

CD Horn Equalizer:

- 20 kHz, 0 to ± 18 dB

Graphic Equalizer:

- 1/3 octave band, 31 center frequencies
- 10 adjustable filters, ± 12 dB
- Q: 0.267 – 69.249 (4 to 1/48th octave)

High-Pass Filter:

- 20 – 20,000 Hz, -12 dB/oct., -6 dB/oct.

High Frequency Shelving Boost or Cut:

- 6 – 20 kHz, ± 12 dB

Low Frequency Shelving Boost or Cut:

- 20 – 500 Hz, ± 12 dB

Low-Pass Filter:

- 20 – 20,000 Hz, -12 dB/oct., -6 dB/oct.

Notch Filter:

- 20 – 20,000 Hz, Q: 8.561 – 69.249 (1/6th to 1/48th octave)

Parametric Filter:

- 20 – 20,000 Hz
- 12 adjustable filters, ± 12 dB
- Q: 0.267 – 69.249 (4 to 1/48th octave)

Bypass Single, Bypass All

Crossover / Channel Divider

- Single (bandpass), 2-way, 3-way, 4-way
- Slope: -6 dB/oct., -12 dB/oct., -18 dB/oct., -24 dB/oct.
- Level: +12 to -12 dB, with Polarity Invert/Normal
- Types:
 - Bessel (-12/-18/-24 dB/oct.)
 - Butterworth (-12/-18/-24 dB/oct.)
 - Linkwitz-Riley (-12/-24 dB/oct.)
 - Variable Q (-12/-18/-24 dB/oct.)

Delay

Driver Alignment Delay (each crossover channel)

- 0 – 682.646 ms
(0 - 761.16 ft./0 -9138.1 in./0 - 232.131 m)

Output Delay (each output channel)

- 0 – 682.646 ms
(0 - 761.16 ft. / 0 -9138.1 in./0 - 232.131 m)

Temperature Calibration:

- Default: 57° F (14° C)

Output Attenuation / Mute (each output)

- Attenuation: 0 to $-\infty$ dB
- Mute: On/Off

*0 dB = 0.775 V

DIMENSIONAL DRAWINGS

DP-0206

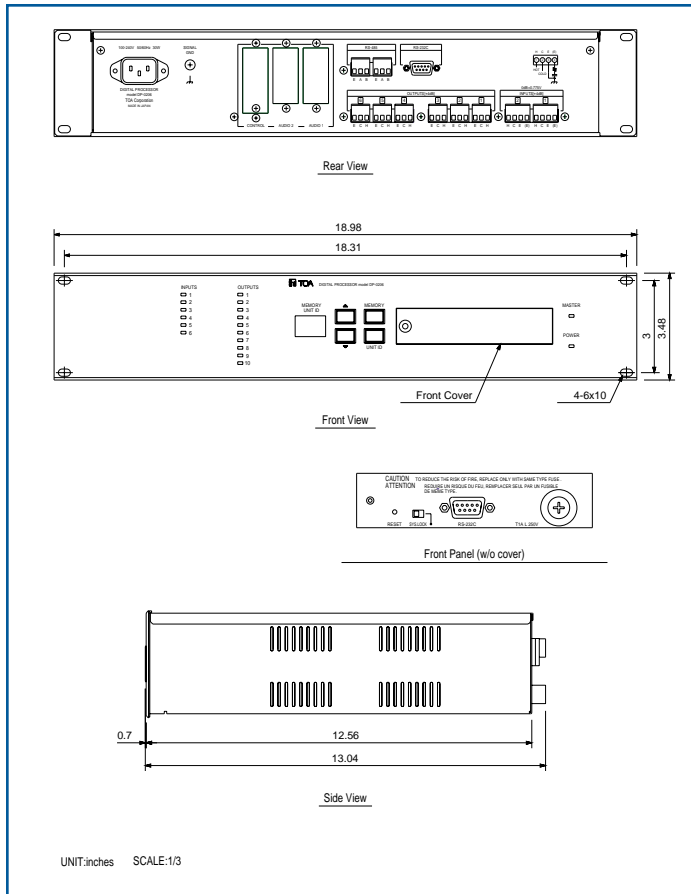

DQ-A01

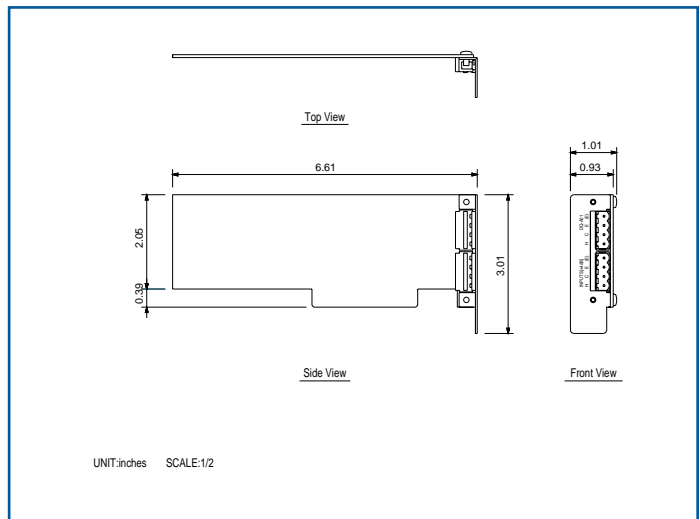

DQ-A02

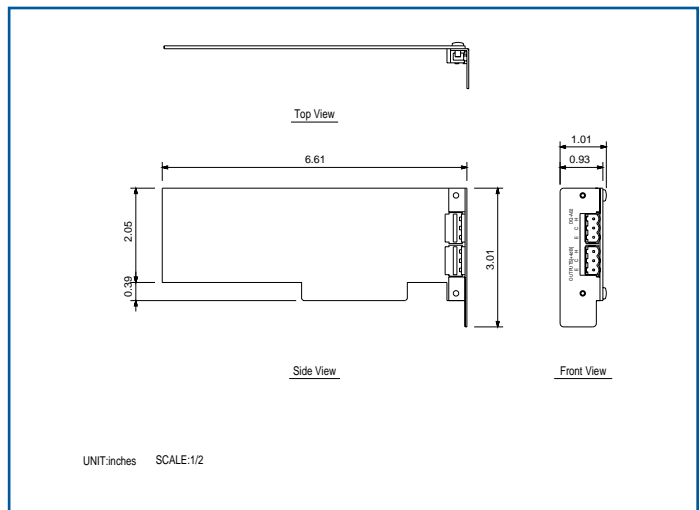

DQ-C01

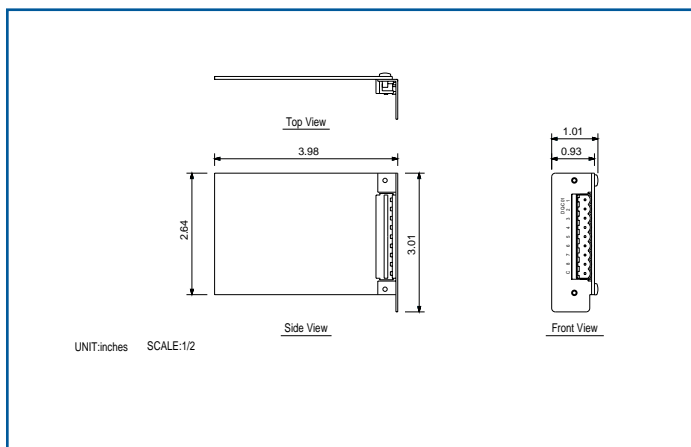

DQ-D01

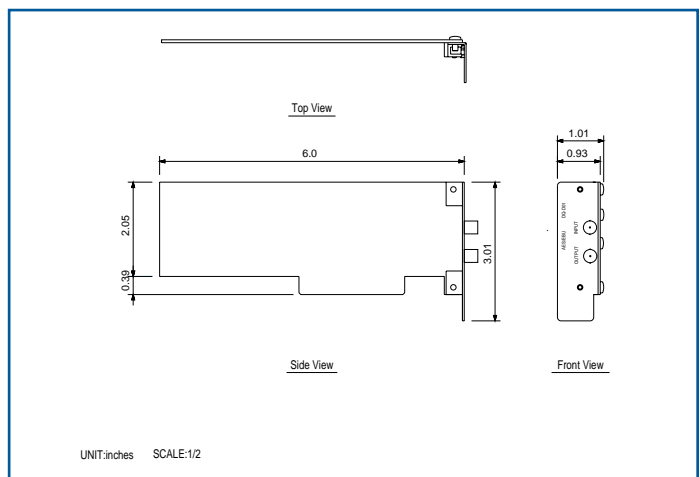

2-INPUT/6-OUTPUT

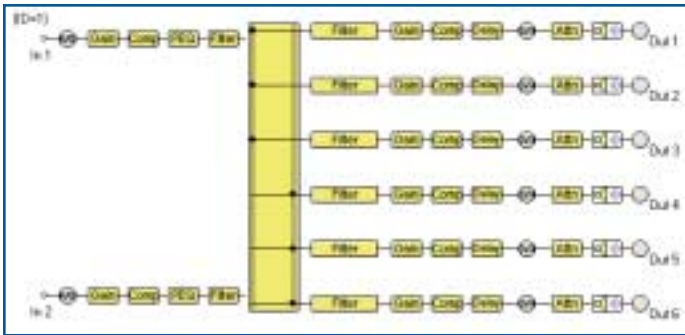

4-INPUT/8-OUTPUT

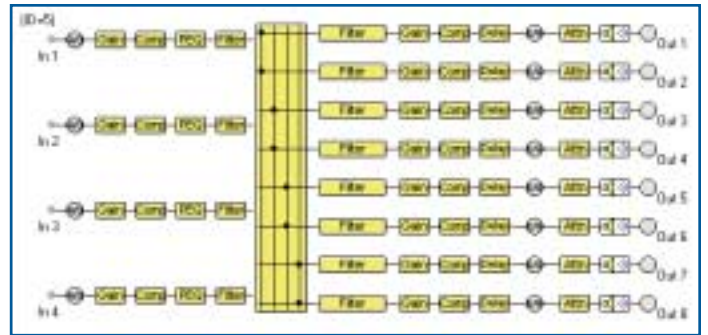

2-INPUT/8-OUTPUT

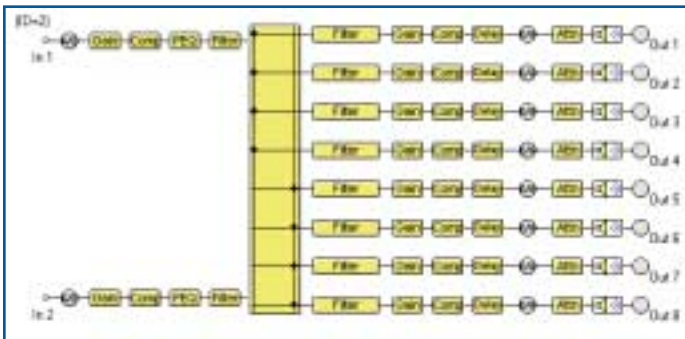

6-INPUT/6-OUTPUT

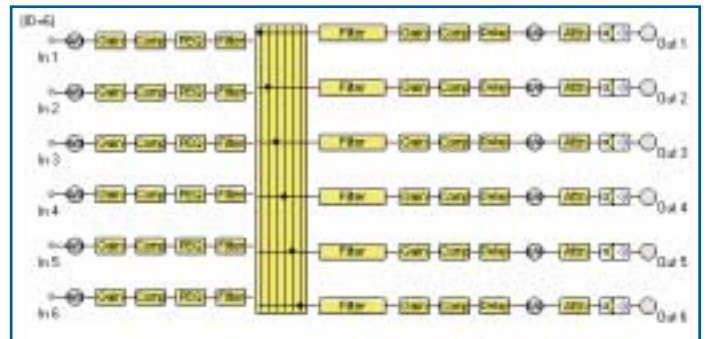

2-INPUT/10-OUTPUT

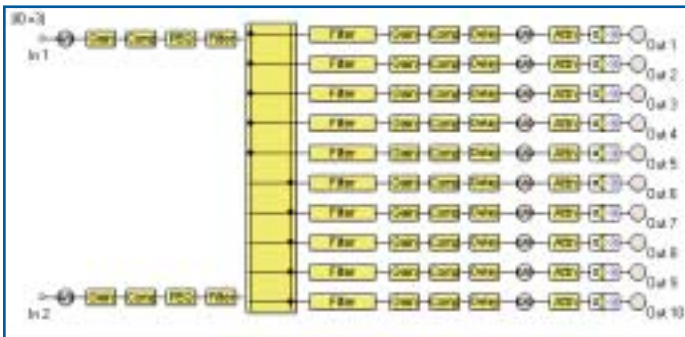

2-INPUT/6-OUTPUT (STEREO 3-WAY CROSSOVER)

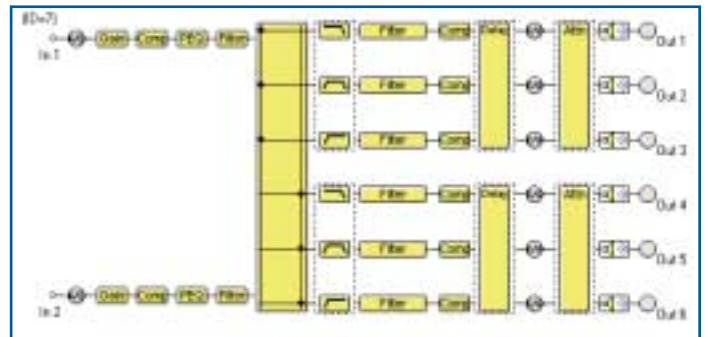

4-INPUT/6-OUTPUT

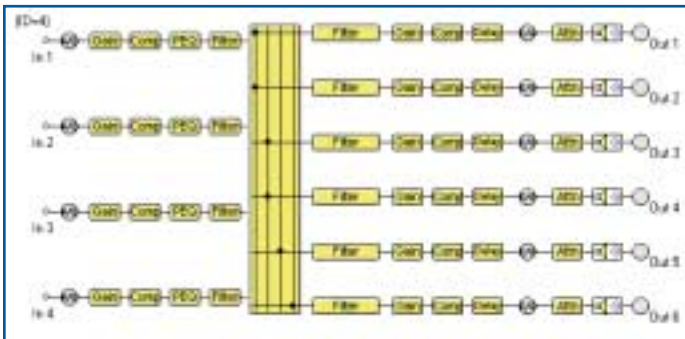

2-INPUT/8-OUTPUT (STEREO 3-WAY CROSSOVER W/ MONO SUBWOOFER AND MONITOR OUTPUTS)

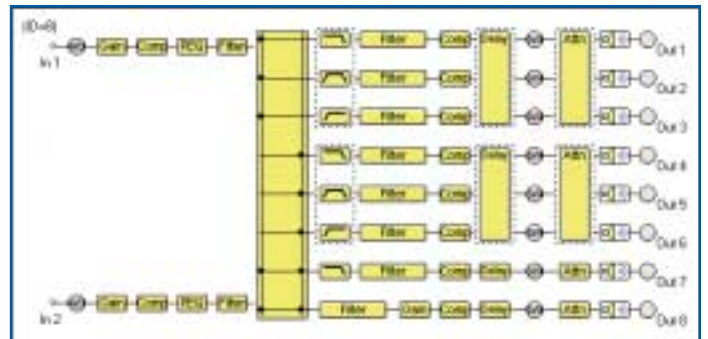

HARDWARE

The digital signal processor shall be from a reputable manufacturer of similar products with proven reliability for a minimum of five years. The unit shall have an internal power supply operating from an AC Mains power source at 50/60 Hz from 100 to 240 VAC with power consumption of 30 W. The unit shall comply with the limits for a Class A computing device pursuant to FCC Part 15, Subject J. The unit shall have a frequency response from 20 to 20,000 Hz ± 1 dB and dynamic range of 110 dB, A-weighted. Total harmonic distortion shall be less than 0.05% from 20 to 20,000 Hz band-pass filtered as measured with a 1 kHz sine wave at +4 dBu. Analog-to-digital and digital-to-analog conversion shall be 24 bit with a sampling frequency of 48 kHz and internal 24 bit digital signal processing.

The unit shall be of modular design to allow for future expansion. The default input/output (I/O) configuration shall be two analog inputs and six analog outputs (2x6) with two I/O module slots allowing five additional I/O configurations: 2x8, 2x10, 4x6, 4x8 and 6x6. Optional input modules shall allow expansion to up to four additional inputs, depending on the number of outputs. Each input shall be electronically-balanced with a nominal input sensitivity of +4 dBu, maximum +24 dBu, input impedance of 10 kohms, and a four-pole removable terminal block connector. Each input shall have two shield connection points - direct-to-chassis and RFI filter-to-chassis. Optional output modules shall allow expansion to up to four additional outputs, depending on the number of inputs. Each output shall be electronically-balanced with a nominal output level of +4 dBu, maximum +24 dBu, capable of driving a minimum load of 600 ohms, and a three-pole removable terminal block connector. Optional input and output modules shall be available to accommodate both analog and digital signals. The analog input and output modules shall have identical electrical characteristics to the main unit. The digital module shall conform to the AES/EBU standard and, via an on-board switch, accept two digital input channels or two digital output channels with BNC-type connectors. The main unit shall accept any combination of two analog or digital modules. The unit shall have one control module slot for an optional control module allowing simultaneous memory selection, output volume control, and output muting, configurable via software.

The unit shall be configured with control software compatible with Microsoft Windows 95/98/Me/NT/2000. The PC communication method shall be serial RS-232 format via either front and rear panel nine-pin, D-sub connector or RS-485 format via two parallel rear panel three-pole removable terminal blocks. Once configured, the unit shall be capable of standalone operation without a PC connection. The unit shall have sixteen on-board memories for recall of stored parameter settings and system configurations, capable of a different configuration in each memory. Memory and firmware storage shall be FLASH-type without requiring an internal backup battery. It shall be possible to update unit firmware via manufacturer-supplied utility update software without disassembling the unit. Memories shall be selected via the unit front panel or dry contact-closure to the optional remote control module. Security settings shall allow the disabling of all front panel controls with multiple levels of software password protection to prevent unauthorized adjustment of system settings or individual processing blocks.

Front panel controls shall include Memory Recall, Unit ID, and Up/Down keys. Front panel indicators shall include Input and Output Level, Memory No./Unit ID, and Master. A front panel security cover shall restrict access to Reset, System Lock, RS-232 port and fuse holder. The unit material and finish shall be Front Panel: aluminum, hair-line finish, black; Case: pre-coated steel plate, black, 30% glossy. The unit dimensions shall be 19" W x 3.5" H x 12.8" D (480 mm x 88.4 mm x 325.2 mm) and the weight shall be 10.3 lbs. (4.65 kg).

SIGNAL PROCESSING

Each input (pre-matrix/router) shall have the following characteristics: Level control providing up to +12 dB of gain with polarity invert and mute. Compressor/limiter with adjustable threshold, ratio, attack time, release time, and synch with configurable ratio to allow peak limiting. A noise gate with adjustable threshold, attack time and release time. Twelve bands of filtering with available types as follows: All-Pass Filter: 20 – 20,000 Hz, adjustable Q: 0.267 – 69.249; CD Horn Equalizer: 20 kHz, adjustable from 0 to ± 18 dB; Graphic Equalizer: 1/3 octave band, 31 center frequencies, 10 adjustable filters, ± 12 dB, adjustable Q: 0.267 – 69.249; High-Pass Filter, 20 – 20,000 Hz, -12 dB/oct., -6 dB/oct.; Low-Pass Filter, from 20 – 20,000 Hz, -12 dB/oct., -6 dB/oct.; High Frequency Shelving Boost or Cut: 6 – 20 kHz, ± 12 dB; Low Frequency Shelving Boost or Cut: 20 – 500 Hz, ± 12 dB; Notch Filter: 20 – 20,000 Hz, adjustable Q: 8.561 – 69.249; Parametric Filter: 20 – 20,000 Hz, 12 adjustable filters, ± 12 dB, adjustable Q: 0.267 – 69.249.

The unit shall include a built-in matrix/router to allow any combination of input-to-output signal routing. Each crosspoint shall have individual on/off, independent level control and polarity inversion.

Each output (post-matrix/router) shall have the following characteristics: Crossover / Channel Divider with available types as follows: Bessel (-12/-18/-24 dB/Oct.), Butterworth (-12/-18/-24 dB/Oct.), Linkwitz-Riley (-12/-24 dB/Oct.) and Variable Q (-12/-18/-24 dB/Oct.). Level: +12 to -12 dB, with polarity invert/normal. Each crossover channel shall have driver alignment delay: 0 – 682.646 ms with adjustable temperature calibration. Up to twelve bands of filtering with available types as described above. Channels configured as high or low-pass crossover channels shall each have ten bands available, band pass (mid-range) crossover channels shall have eight bands available. Compressor/limiter and noise gate, identical to the input type described above. Output delay: 0 – 682.646 ms with adjustable temperature calibration. An analog output attenuator, VCA-type and relay-controlled output mute.

The digital signal processor shall be the TOA DP-0206.

The dual analog input module shall be the TOA DQ-A01.

The dual analog output module shall be the TOA DQ-A02.

The dual digital input/output module shall be the TOA DQ-D01.

The remote control module shall be the TOA DQ-C01.