



## OPERATING INSTRUCTIONS

# MIXER POWER AMPLIFIER

**BG-1015**

**BG-1030**

**BG-1060**

**BG-1120**

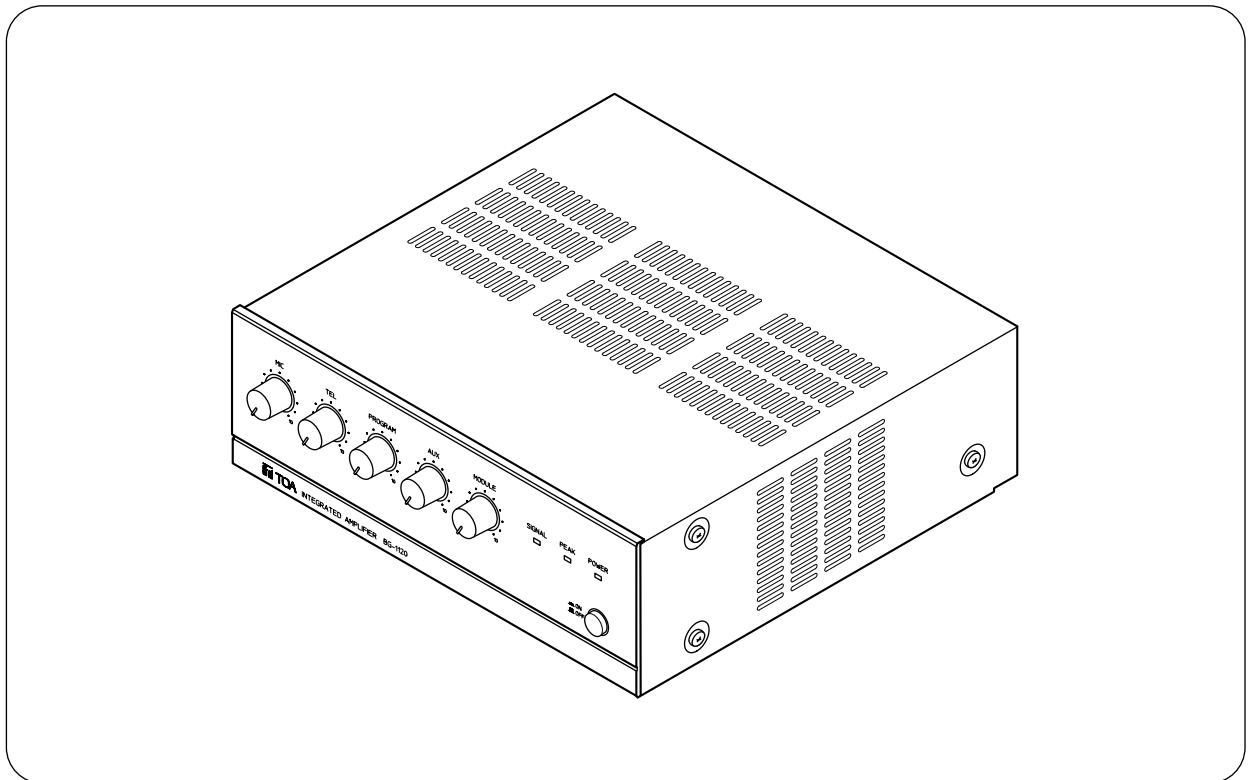

Please follow the instructions in this manual to obtain the optimum results from this unit.  
We also recommend that you keep this manual handy for future reference.

**TOA Corporation**

# IMPORTANT SAFETY INSTRUCTIONS

- Be sure to read these instructions in this section carefully before use.
- Heed all warnings and follow all instructions.
- Keep these instructions handy for reference at any time.
- Do not block any of the ventilation openings. Install in accordance with the manufacturer's instructions.
- Do not install near any heat sources such as radiators, heat registers, stoves, or other apparatus (including amplifiers) that produce heat.
- Do not defeat the safety purpose of the polarized or grounding type plug. A polarized plug has two blades with one wider than the other. A grounding type plug has two blades and a third grounding prong. The wide blade or the third prong is provided for your safety. When the provided plug does not fit into your outlet, consult an electrician for replacement of the obsolete outlet.
- Protect the power cord from being walked on or pinched particularly at plugs, convenience receptacles, and the point where they exit from the apparatus.
- Only use the attachments or accessories specified by the manufacturer.
- Use only with a cart, stand, tripod, bracket, or table specified by the manufacturer, or sold with the apparatus. When a cart is used, use caution when moving the cart/apparatus combination to avoid injury from tip-over.
- Unplug this apparatus during lightning storms or when unused for long periods of time.
- Refer all servicing to qualified service personnel. Servicing is required when the apparatus has been damaged in any way, such as power supply cord or plug is damaged, liquid has been spilled or objects have fallen into the apparatus, the apparatus has been exposed to rain or moisture, does not operate normally, or has been dropped.
- Do not use this apparatus near water.
- Clean only with a dry cloth.

## SAFETY PRECAUTIONS

- Be sure to read the instructions in this section carefully before use.
- Make sure to observe the instructions in this manual as the conventions of safety symbols and messages regarded as very important precautions are included.
- We also recommend you keep this instruction manual handy for future reference.

### Safety Symbol and Message Conventions

Safety symbols and messages described below are used in this manual to prevent bodily injury and property damage which could result from mishandling. Before operating your product, read this manual first and understand the safety symbols and messages so you are thoroughly aware of the potential safety hazards.



Indicates a potentially hazardous situation which, if mishandled, could result in death or serious personal injury.



Indicates a potentially hazardous situation which, if mishandled, could result in moderate or minor personal injury, and/or property damage.



#### When Installing the Unit

- Do not expose the unit to rain or an environment where it may be splashed by water or other liquids, as doing so may result in fire or electric shock.
- Use the unit only with the voltage specified on the unit. Using a voltage higher than that which is specified may result in fire or electric shock.
- Do not cut, kink, otherwise damage nor modify the power supply cord. In addition, avoid using the power cord in close proximity to heaters, and never place heavy objects -- including the unit itself -- on the power cord, as doing so may result in fire or electric shock.

- Be sure to replace the unit's terminal cover after connection completion. Because high voltage is applied to the speaker terminals, never touch these terminals to avoid electric shock.
- Avoid installing or mounting the unit in unstable locations, such as on a rickety table or a slanted surface. Doing so may result in the unit falling down, causing personal injury and/or property damage.

#### When the Unit is in Use

- Should the following irregularity be found during use, immediately switch off the power, disconnect the power supply plug from the AC outlet and contact your nearest TOA dealer. Make no further attempt to operate the unit in this condition as this may cause fire or electric shock.
  - If you detect smoke or a strange smell coming from the unit.
  - If water or any metallic object gets into the unit
  - If the unit falls, or the unit case breaks
  - If the power supply cord is damaged (exposure of the core, disconnection, etc.)
  - If it is malfunctioning (no tone sounds.)
- To prevent a fire or electric shock, never open nor remove the unit case as there are high voltage components inside the unit. Refer all servicing to your nearest TOA dealer.
- Do not place cups, bowls, or other containers of liquid or metallic objects on top of the unit. If they accidentally spill into the unit, this may cause a fire or electric shock.
- Do not insert nor drop metallic objects or flammable materials in the ventilation slots of the unit's cover, as this may result in fire or electric shock.

### CAUTION

#### When Installing the Unit

- Never plug in nor remove the power supply plug with wet hands, as doing so may cause electric shock.

### ATTENTION

- When unplugging the power supply cord, be sure to grasp the power supply plug; never pull on the cord itself. Operating the unit with a damaged power supply cord may cause a fire or electric shock.
- When moving the unit, be sure to remove its power supply cord from the wall outlet. Moving the unit with the power cord connected to the outlet may cause damage to the power cord, resulting in fire or electric shock. When removing the power cord, be sure to hold its plug to pull.
- Avoid installing the unit in humid or dusty locations, in locations exposed to the direct sunlight, near the heaters, or in locations generating sooty smoke or steam as doing otherwise may result in fire or electric shock.

#### When the Unit is in Use

- Do not place heavy objects on the unit as this may cause it to fall or break which may result in personal injury and/or property damage. In addition, the object itself may fall off and cause injury and/or damage.
- Make sure that the volume control is set to minimum position before power is switched on. Loud noise produced at high volume when power is switched on can impair hearing.
- Do not operate the unit for an extended period of time with the sound distorting. This is an indication of a malfunction, which in turn can cause heat to generate and result in a fire.
- Contact your TOA dealer as to the cleaning. If dust is allowed to accumulate in the unit over a long period of time, a fire or damage to the unit may result.
- If dust accumulates on the power supply plug or in the wall AC outlet, a fire may result. Clean it periodically. In addition, insert the plug in the wall outlet securely.
- Switch off the power, and unplug the power supply plug from the AC outlet for safety purposes when cleaning or leaving the unit unused for 10 days or more. Doing otherwise may cause a fire or electric shock.

L'appareil ne doit pas être exposé aux éclaboussures ou écoulements et tous objets remplis de liquide, tels que vases, ne doivent pas être sur l'appareil.

# TABLE OF CONTENTS

<b>1. GENERAL DESCRIPTION</b>	5
<b>2. FEATURES</b>	5
<b>3. NOMENCLATURE AND FUNCTIONS</b>	
Front	6
Rear	7
<b>4. INPUT CONNECTIONS</b>	8
<b>5. OUTPUT CONNECTIONS</b>	9
<b>6. PLUG-IN MODULE INPUT PORT</b>	
6.1. Module Installation	9
6.2. Module Selector Switch Settings	10
<b>7. EQUIPMENT SETTINGS</b>	
7.1. Mute Function	
7.1.1. Mute operation A	10
7.1.2. Mute operation B	11
7.2. TEL Input Impedance Selection	11
7.3. AUX, PROGRAM, MODULE (BGM) Output Selection	12
7.4. Phantom Power On/Off Setting for Microphone Input	12
7.5. Changing MIC and PROGRAM Input Types	
7.5.1. MIC input	12
7.5.2. Program input	13
<b>8. INSTALLATION</b>	13
<b>9. RACK MOUNTING</b>	13
<b>10. CONTROL SETTINGS</b>	14
<b>11. DIMENSIONAL DIAGRAM</b>	14
<b>12. BLOCK DIAGRAM</b>	15
<b>13. SPECIFICATIONS</b>	16
Accessories	16
Optional products	16

## 1. GENERAL DESCRIPTION

TOA's BG-1015, BG-1030, BG-1060, and BG-1120 Mixer Power Amplifiers can mix up to a total of 5 independent input signals. Power output is rated at 15 W for the BG-1015, 30 W for the BG-1030, 60 W for the BG-1060, and 120 W for the BG-1120. All units are ideal for use in sound systems requiring small power outputs.

## 2. FEATURES

- 3 balanced inputs, 1 unbalanced input, and 1 module input
- Phantom-powered microphone input
- Telephone paging input
- Compatible with all 900 Series modules (except for mute buss functions)
- Wide frequency response ranging from 50 Hz to 20 kHz
- Low distortion and low noise level
- Excellent output regulation
- Three different speaker outputs: 4  $\Omega$ , 25 V, and 70 V
- MOH (Music On-Hold) output: 1 V, 600  $\Omega$
- 1W output terminal: 8  $\Omega$
- Independent bass and treble controls
- Input and output terminals for connection of signal processors
- Two different mute functions
- Overcurrent and thermal protection circuitries
- Compact and lightweight
- Desktop or 19" rack mountable

### 3. NOMENCLATURE AND FUNCTIONS

[Front]

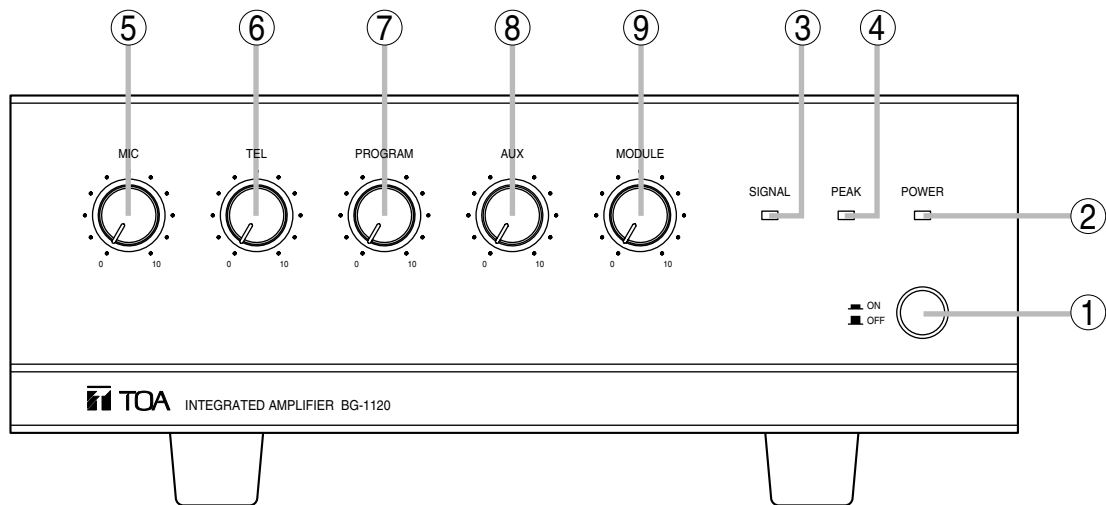

This figure represents the BG-1120.

#### 1. Power switch

Press to turn ON the power. Press again to turn the power OFF.

#### Note

Amplifier operation is enabled about 3 seconds after the power switch is pressed.

#### 2. Power indicator

Lights green when the power is switched on.

#### 3. Signal level indicator

Lights green when the speaker output signal level exceeds 20 dB.

#### 4. Peak indicator

Lights when the output signal level exceeds the point at which the signal begins to distort. If this indicator remains lit, reduce the volume at each volume control so that the indicator only lights momentarily.

#### 5. Microphone input volume control

Adjusts the microphone input volume. Turn clockwise to increase and counterclockwise to decrease.

#### 6. Telephone paging input volume control

Adjusts the telephone paging input volume. Turn clockwise to increase and counterclockwise to decrease.

#### 7. Program input volume control

Adjusts the Program input volume. Turn clockwise to increase and counterclockwise to decrease.

#### 8. AUX input volume control

Adjusts the AUX input volume. Turn clockwise to increase and counterclockwise to decrease.

#### 9. Module input volume control

Adjusts the Module input volume. Turn clockwise to increase and counterclockwise to decrease.

#### Protection function to be noted on operation

When the temperature of unit's internal heat sink exceeds the specified limit, the protection circuit is activated and the output is disconnected from the circuit. Output is automatically restored when the heat sink cools down below the temperature limit.

[Rear]

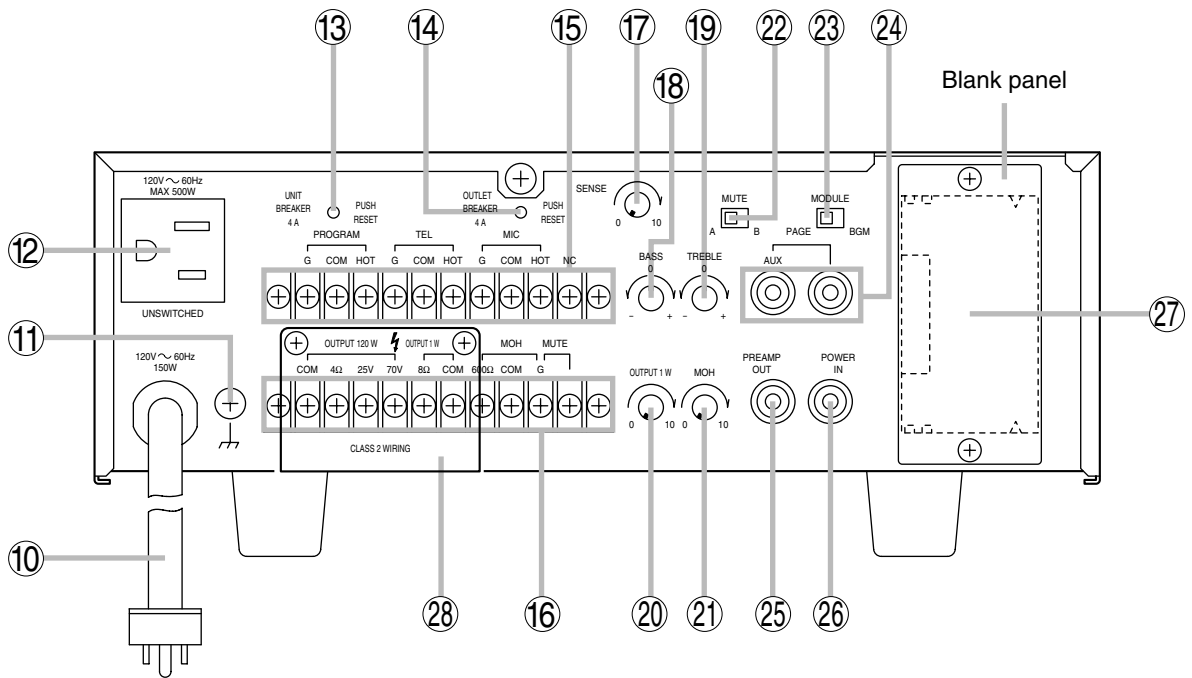

This figure represents the BG-1120.

**10. Power cord**

Connect this cord to an AC outlet of 120 V AC.

**11. Ground terminal**

A functional ground terminal.

**12. AC outlet [UNSWITCHED]**

Continuously supplies up to 500 W of AC power to connected external equipment.

**13. Breaker [UNIT]**

Cuts off the AC power to the unit when its input current exceeds the allowable value.

**Note**

The yellow button in the breaker pops out to indicate that the breaker has tripped. After turning off the power and eliminating the cause of the breaker trip, press the button to reset the breaker.

**14. Breaker [OUTLET]**

Cuts off the AC power supply from the AC outlet if current output exceeds 4 A.

**Note**

The yellow button in the breaker pops out to indicate that the breaker has tripped. After turning off the power and eliminating the cause of the breaker trip, press the button to reset the breaker.

**15. Input terminal block**

Used for connection of MIC, TEL and PROGRAM inputs. (Refer to p. 8.)

**16. Output terminal block**

Used for connection of speaker outputs, 1 W output, MOH (Music On-Hold) output, and Mute control signals. (Refer to p. 9 and p. 10.)

**17. Sensitivity control**

Adjusts the sensitivity of the mute circuit. Rotate clockwise to increase sensitivity, and counterclockwise to reduce sensitivity.

**18. Bass control**

Adjusts the bass frequency band level of speaker outputs for MODULE (BGM), PROGRAM, and AUX input signals. Rotate clockwise to increase bass output, and counterclockwise to reduce it. The center position provides flat characteristics.

**19. Treble control**

Adjusts the treble frequency band level of speaker outputs for MODULE (BGM), PROGRAM, and AUX input signals. Rotate clockwise to increase treble output, and counterclockwise to reduce it. The center position provides flat characteristics.

**20. 1 W output volume control**

Adjusts the 1 W OUTPUT level. Rotate clockwise to increase and counterclockwise to decrease.

**21. MOH output volume control**

Adjusts the MOH (Music On-Hold) output signal level. Rotate clockwise to increase and counterclockwise to decrease.

**22. Mute selector switch**

Changes the type of mute operation. (Refer to p. 10.)

**23. Module selector switch**

Selects the output terminal for the module signal. Set the switch to the PAGE position when using the paging module, and to the BGM position when using the BGM module.

**24. AUX input terminals (2P RCA pin jack)**

An internal mixing type of jack. Used for connection of external equipment input signals. (Refer to p. 8.)

**25. Preamplifier output terminal [PREAMP OUT]**

Used for connection of output signals to external signal processing equipment such as limiters and equalizers.

**26. Power amplifier input terminal [POWER IN]**

Used for connection of input signals from external signal processing equipment such as limiters and equalizers.

**27. Module input port**

Optional 900 Series modules can be installed here.

**Note**

For details concerning 900 Series modules, contact your nearest TOA dealer.

**28. Terminal cover**

Make sure that the terminal cover is reattached after speaker output terminal connection completion.

**4. INPUT CONNECTIONS**

**[MIC input connections]**

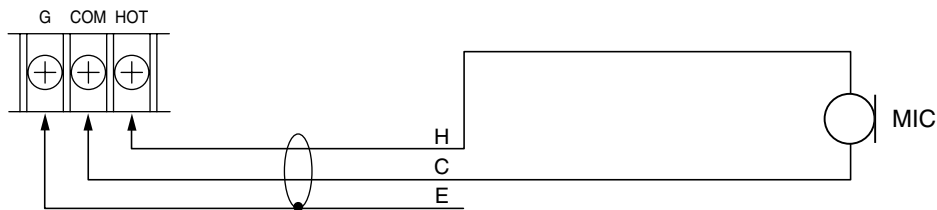

**[TEL and PROGRAM input connections]**

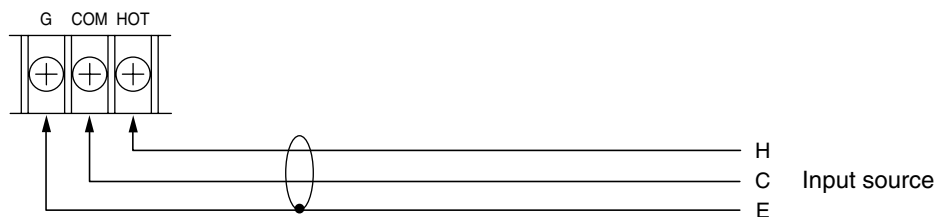

**[AUX input connections]**

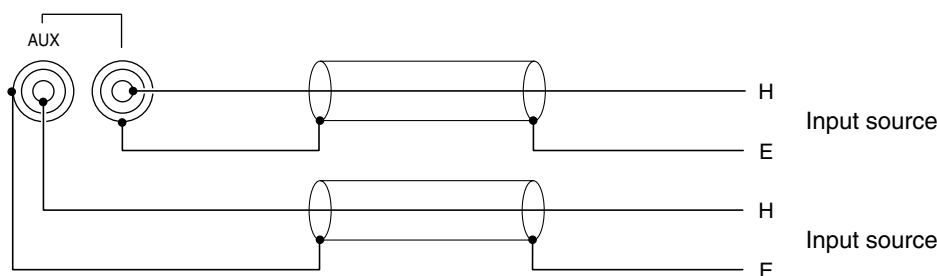



## 5. OUTPUT CONNECTIONS

### [Output terminals]

Each amplifier has 3 speaker outputs: 4 Ω, 25 V and 70 V. Use only one of these outputs for connection. Class 2 wiring may be used.

**Note:** The impedance in the figure below represents the total impedance of the speaker system.

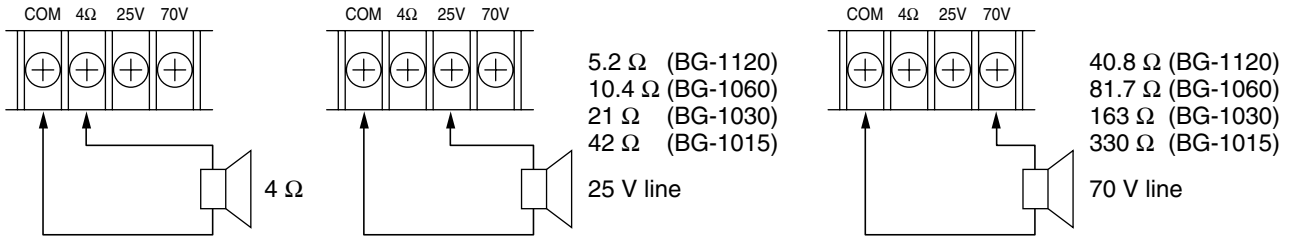

### [MOH output connections]

The MOH output is rated at 1 V/600 Ω

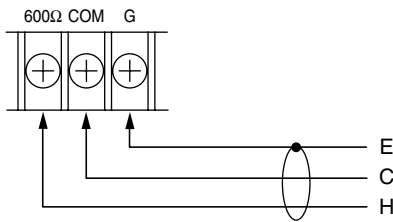

### [OUTPUT 1 W output connections]

The OUTPUT 1 W output is rated at 1 W/8 Ω

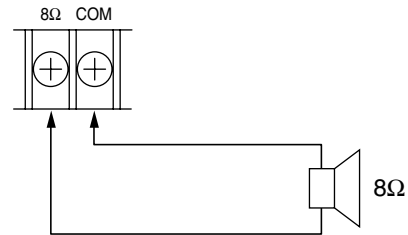

## 6. PLUG-IN MODULE INPUT PORT

A single port for TOA plug-in modules is located on the unit's rear panel. Any 900 Series plug-in module can be inserted into this port.

**Note:** Consult your nearest TOA dealer for selection of appropriate module types.

Be sure to turn off the power before performing the following operations:

### 6.1. Module Installation

- Step 1.** Remove the blank panel covering the module slot on the rear panel.
- Step 2.** Align the module board with the top and bottom guide rails, and press in.
- Step 3.** Using the screws supplied with the module, secure the module to the rear panel.

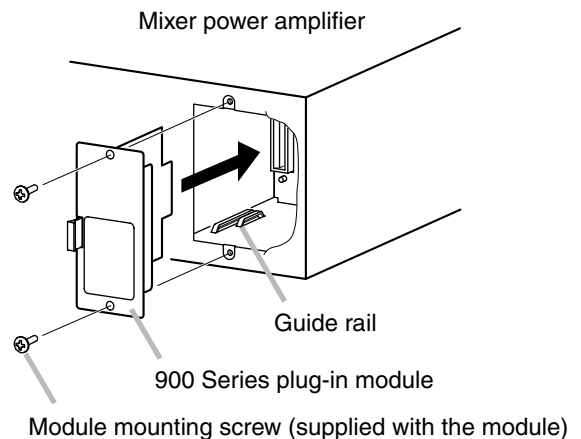

## 6.2. Module Selector Switch Settings

Set the rear panel-mounted Module Selector Switch to either the PAGE or BGM position, depending on the output terminal to which the module signal is to be sent.

**PAGE:** Signals from the installed module are only sent to the speaker outputs.

**BGM:** The terminal to which the signal from the module is to be output differs depending on jumper wire settings inside the unit. (Refer to p. 12.)

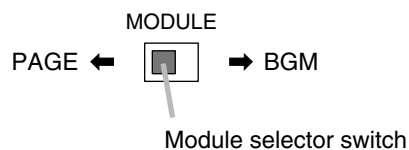

Set both the bass and treble controls to the center position when using the equalizer module.

**Caution:** Make sure that the supplied blank panel is placed over the connector port when the port is not in use.

## 7. EQUIPMENT SETTINGS

**Caution:** Be sure to leave settings to a qualified technician.

### 7.1. Mute Function

The unit features 2 different mute functions, A and B. Mute A or B can be selected with the rear panel-mounted Mute Selector Switch.

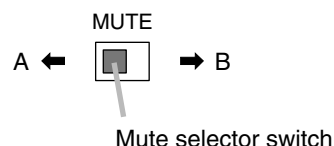

#### 7.1.1. Mute operation A

The mute function can be activated either by the TEL, MIC, or MODULE (PAGE) input signal, or by shorting the rear panel-mounted mute terminals.

##### [Mute signal settings]

Input signals to activate the mute function can be selected by the internal jumper wire settings. The TEL, MIC, and MODULE (PAGE) input signals are all factory-preset (Jumpers JP207, JP208, and JP209 are set) as muting signals.

Cut off the jumper wire corresponding to the input signal to be disabled for muting.

In any case, shorting the rear-mounted Mute terminals can also actuate the mute function.

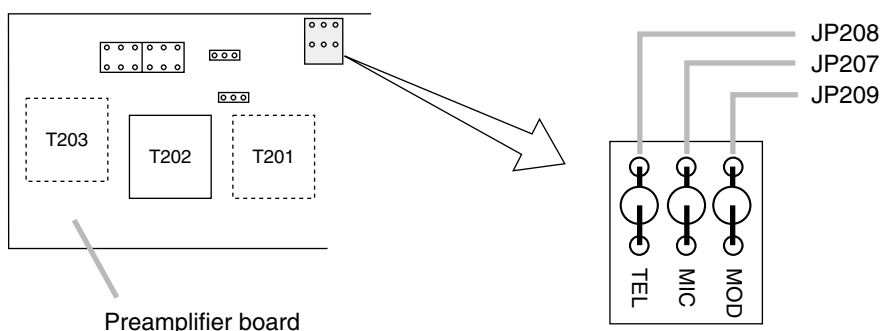

##### Note

If Module Input is selected, the mute function can only be used when the Module Selector Switch is set to the PAGE position.

**[Muted signal settings]**

Use the unit's internal jumper switch JP301 to select the signal to be muted. Select either the input signal from the TEL, MIC, and MODULE (PAGE) terminals or from the AUX, PROGRAM, and MODULE (BGM) terminals as the signal to be muted.

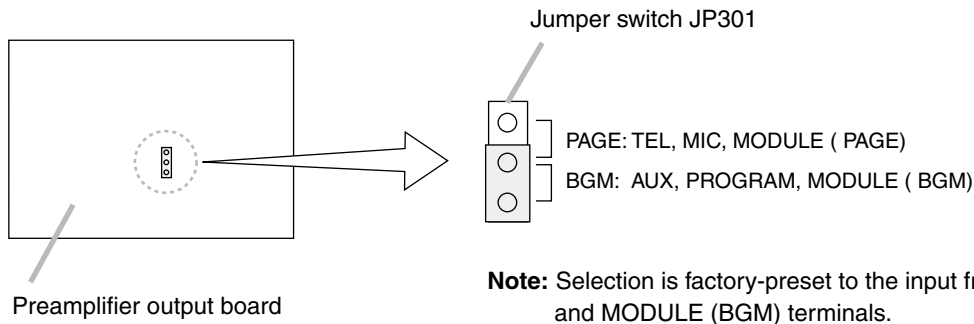

**7.1.2. Mute operation B**

The mute function can be controlled by way of the rear panel-mounted Mute terminal.

**Note:** The mute function cannot be controlled by means of an input signal.

**[Mute terminal]**

✓ : Channel is ON.    × : Signal is muted.

Open		Close	
MIC	×	MIC	✓
TEL		TEL	
MODULE (PAGE)		MODULE (PAGE)	
AUX	✓	AUX	×
PROGRAM		PROGRAM	
MODULE (BGM)		MODULE (BGM)	

**7.2. TEL Input Impedance Selection**

The impedance is factory-preset to 10 kΩ. To switch to 600 Ω, change the position of the unit's internal jumper switch JP204.

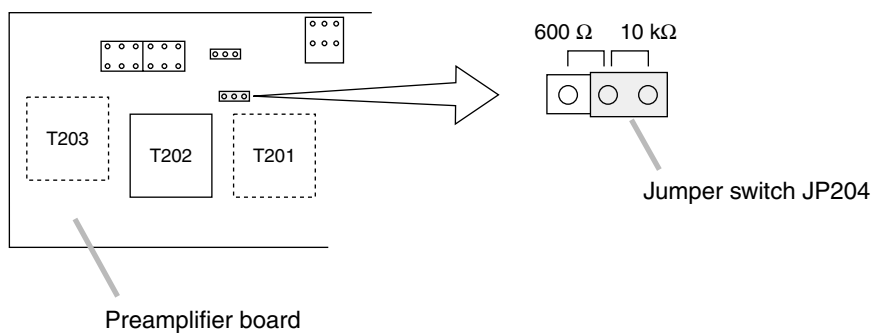

### 7.3. AUX, PROGRAM, MODULE (BGM) Output Selection

Operations shown in the following table can be enabled with the unit's internal jumper settings.

[OUTPUT 15 W/30 W/60 W/120 W]

JP210	Jumpered	AUX:	ON
	Cut	AUX:	OFF
JP211	Jumpered	PROGRAM:	ON
	Cut	PROGRAM:	OFF
JP212	Jumpered	MODULE (BGM):	ON
	Cut	MODULE (BGM):	OFF

[OUTPUT 1 W, MOH]

JP213	Jumpered	AUX:	ON
	Cut	AUX:	OFF
JP214	Jumpered	PROGRAM:	ON
	Cut	PROGRAM:	OFF
JP215	Jumpered	MODULE (BGM):	ON
	Cut	MODULE (BGM):	OFF

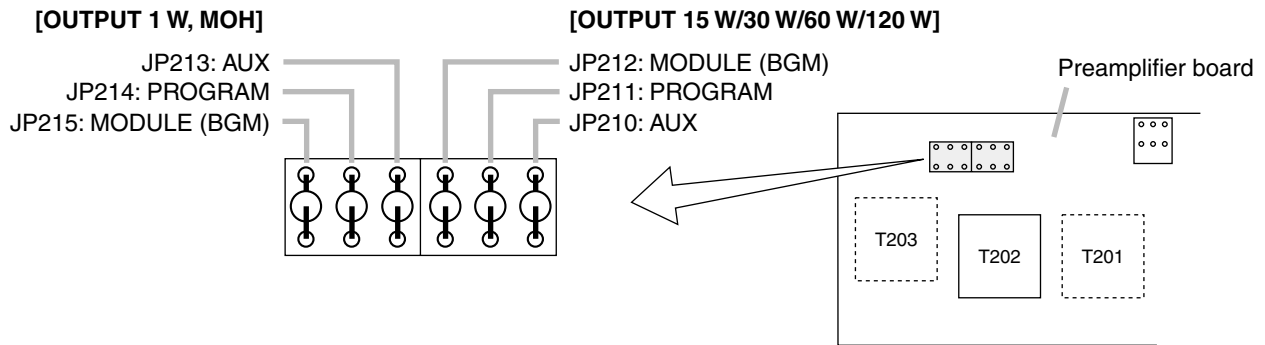

### 7.4. Phantom Power On/Off Setting for Microphone Input

The phantom power is set for ON or OFF by the unit's internal jumper switch JP201. It is factory-preset for OFF.

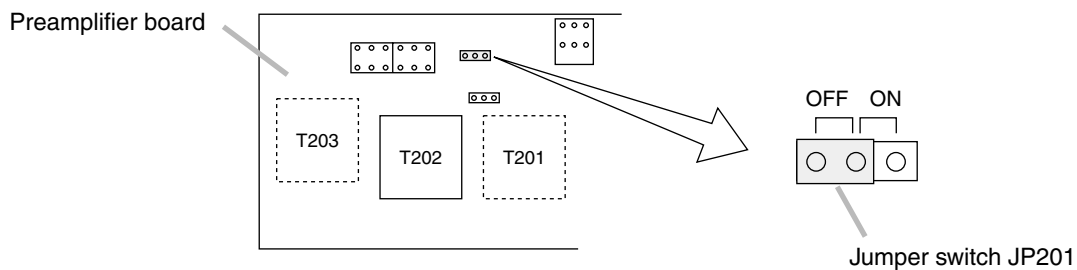

### 7.5. Changing MIC and PROGRAM Input Types

Both MIC and PROGRAM inputs can be changed from electronically-balanced to transformer-balanced types in the procedures as follows.

#### 7.5.1. MIC input

- Install an optional IT-450 Line Transformer in the specified location on the printed circuit board.
- Cut off the JP202 and JP203 jumper wires.

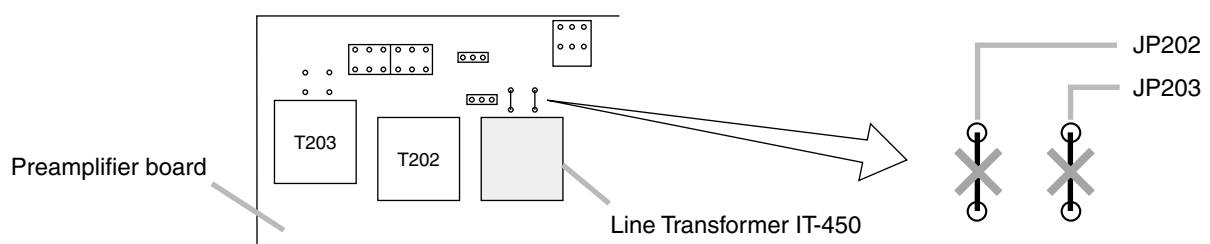

### 7.5.2. Program input

- Install an optional IT-453A Line Transformer in the specified location on the printed circuit board.
- Cut off the JP205 and JP206 jumper wires.

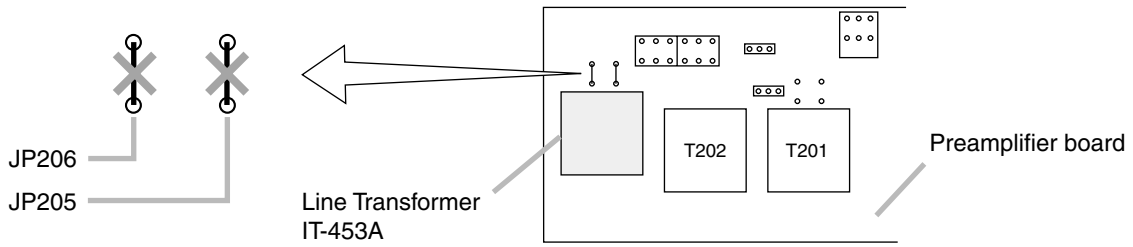

## 8. INSTALLATION

Keep the unit's all sides at least 10 cm away from objects that may obstruct air flow to prevent the unit's temperature from rising.

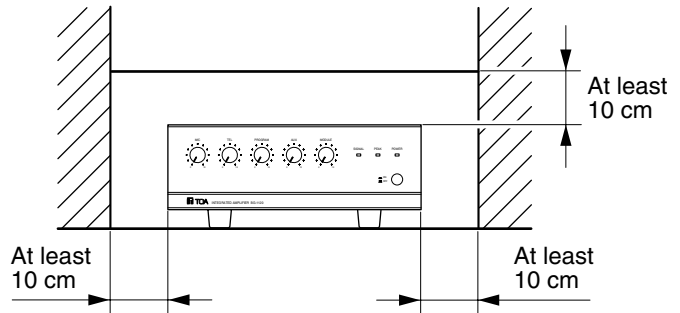

## 9. RACK MOUNTING

To mount the amplifier in a standard 19" equipment rack, use the optional MB-1000 Rack Mounting Kit. Attach the MB-1000 to the amplifier using the supplied 4 screws. When using other screws, ensure that each screw is shorter than 16 mm.

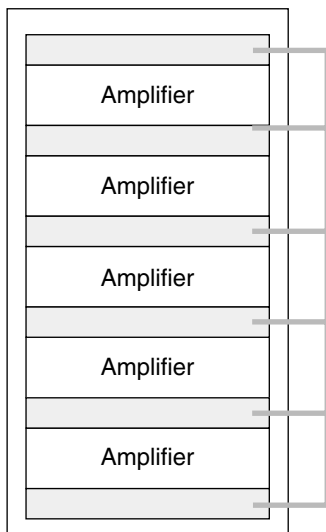
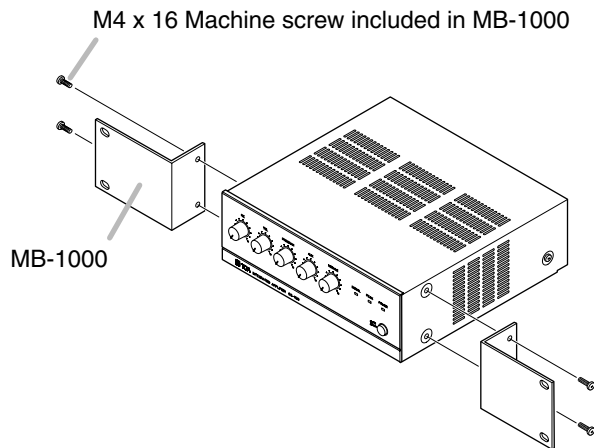

PF-511 Perforated Panel (1-unit size)

**Note**

Mount the Perforated Panel PF-511 above and below each amplifier for ventilation inside the rack.

About the perforated panel, consult your TOA dealer.

## 10. CONTROL SETTINGS

Output levels are adjustable with individual volume controls. For music play or announcement, adjust the corresponding volume control so that the signal indicator lights intermittently. Note that the sound quality is downgraded when the peak indicator remains lit.

To prevent the accidental change of the settings of input volume controls, remove their knobs after setting them to the desired position and attach the volume control covers instead.

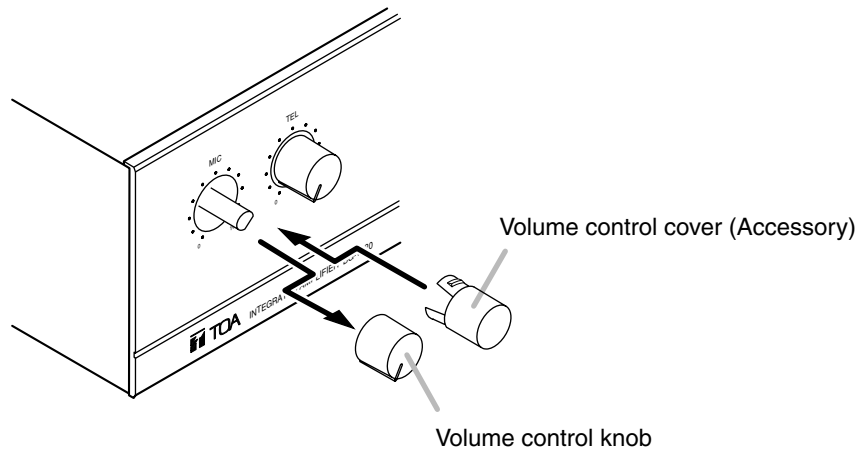

## 11. DIMENSIONAL DIAGRAM (Applicable to all models)

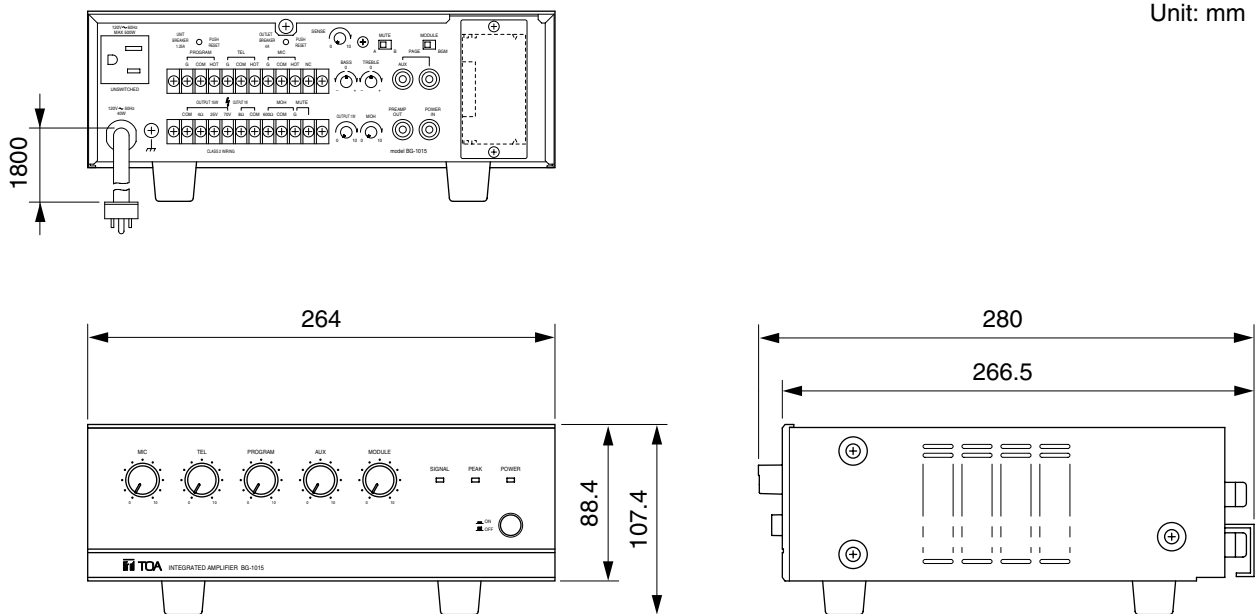

# 12. BLOCK DIAGRAM

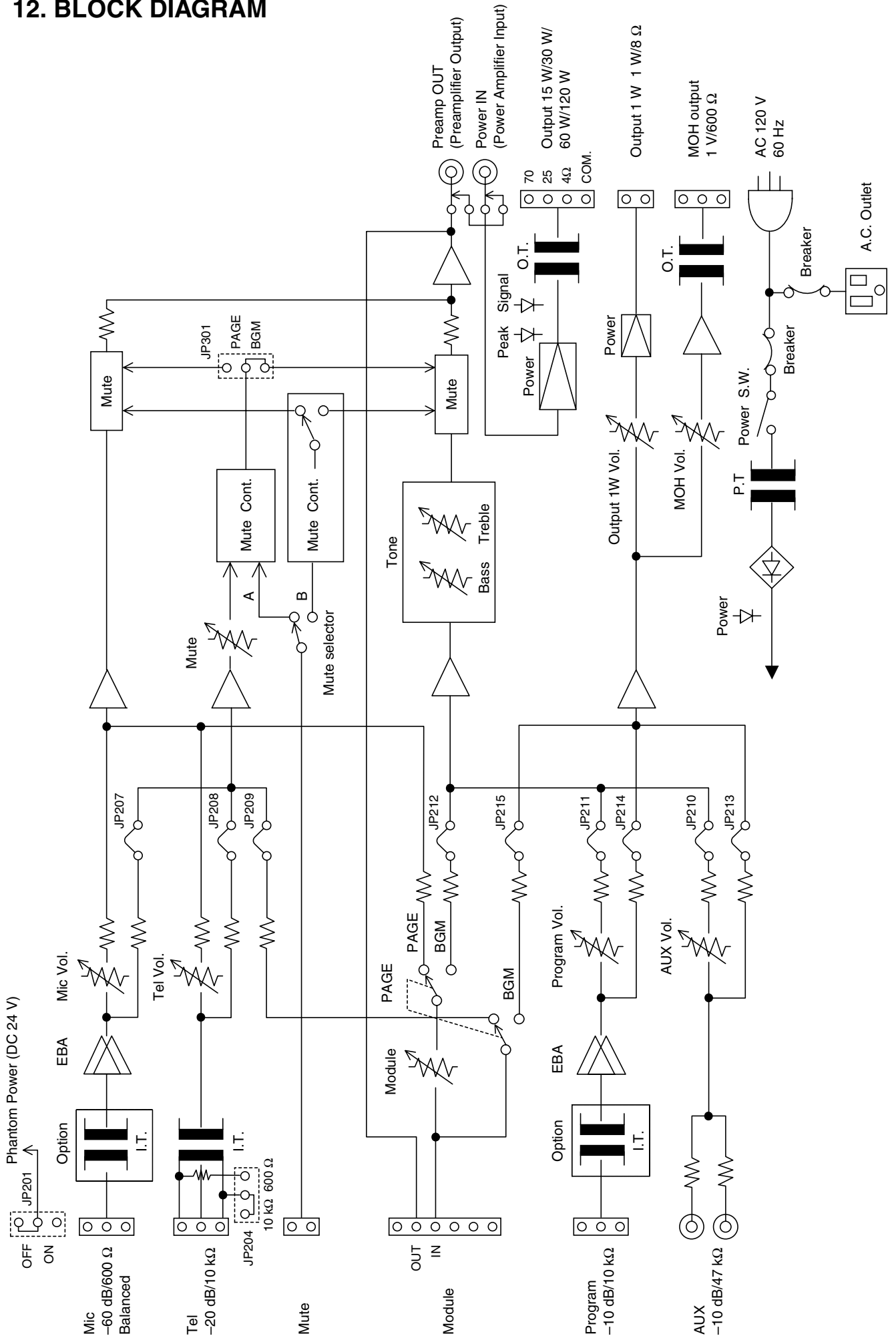

### 13. SPECIFICATIONS

Model No.	BG-1015	BG-1030	BG-1060	BG-1120
Power Source	120 V AC, 60 Hz			
Rated Output	15 W	30 W	60 W	120 W
Power Consumption				
Rated output	50 W	80 W	160 W	260 W
Based on UL/CSA standards	40 W	60 W	100 W	150 W
Frequency Response	50 – 20,000 Hz			
Total Harmonic Distortion	0.05% at 1 kHz, rated output			
Input	Mic: –60 dB* <sup>1</sup> , 600 Ω, electrically balanced, M3 screw terminal* <sup>2</sup> Tel: –20 dB* <sup>1</sup> , 10 kΩ/600 Ω, balanced, M3 screw terminal* <sup>2</sup> Program: –10 dB* <sup>1</sup> , 10 kΩ, electrically-balanced, M3 screw terminal* <sup>2</sup> Aux: –10 dB* <sup>1</sup> , 47 kΩ, unbalanced, 2P RCA pin jack (internal mixing) Module: –20 dB* <sup>1</sup> , 10 kΩ, unbalanced, card edge connector Power IN: 0 dB* <sup>1</sup> , 10 kΩ, unbalance, RCA pin jack Mute: M3 screw terminal* <sup>2</sup>			
Output	Main: 4 Ω, 25 and 70 V, balanced, M3 screw terminal* <sup>2</sup> Sub: 1 W/8 Ω, unbalanced, M3 screw terminal* <sup>2</sup> MOH: 0 dB* <sup>1</sup> , 600 Ω, balanced, M3 screw terminal* <sup>2</sup> Preamp OUT: 0 dB* <sup>1</sup> , 600 Ω, unbalance, RCA pin jack			
Output Regulation	Under 2 dB, no load to full load			
S/N Ratio	Mic: 60 dB, Telephone: 75 dB, Program: 75 dB, Aux: 75 dB, Module: 75 dB (Band Pass: 20 – 20,000 Hz, Tone Controls: Centered)			
Tone Controls	Bass: ±10 dB at 100 Hz, Treble: ±10 dB at 10 kHz Controls affect only program input, aux input and module (BGM) input			
Cooling Fan Speed	—		Variable by heat sink temperature	
Indicator	Power LED, Signal LED, Peak LED			
Protection	Self protection, with 1 AC breaker (outside)			
Other Feature	Automatic electronic drive limiter Output disconnected for approx. 3 seconds after the unit is turned on			
Finish	Panel: ABS resin, black Case: Steel plate, black, paint			
Dimensions	264 (w) x 107.4 (h) x 280 (d) mm			
Weight (without input module)	4.5 kg	4.8 kg	5.6 kg	6.4 kg

\*<sup>1</sup> 0 dB = 1 V

\*<sup>2</sup> Distance between barriers on the above screw terminal: 6 mm

**Note:** The design and specifications are subject to change without notice for improvement.

• **Accessories**

Volume control cover ..... 5

• **Optional products**

Line transformer: IT-450  
Line transformer: IT-453A