



INTERCOM SYSTEM

TOA EXES-1000 INTERCOM SYSTEM

INSTALLATION HAND BOOK

&
TROUBLE SHOOTING



TOA ELECTRIC CO., LTD.

KOBE, JAPAN

CONTENTS

	Page
1. Introduction	3
2. Introduction of the EXES-1000 System	4
2-1. Exchange	4
2-1-1. Features	4
2-1-2. Specifications	5
2-1-3. Further Details	6
2-1-4. Installation of Each Unit	17
2-2. Stations	19
2-2-1. Features	19
2-2-2. Specifications	19
2-3. Accessories	21
2-3-1. Talk-Back Unit (TKU-11)	21
2-3-2. Wall Mounting Panel (YC-100)	21
3. Installation of the EXES-1000 System	23
3-1. Exchange	23
3-2. Stations	27
3-3. Accessories	28
4. Cable Installation and Connection	30
4-1. Cable Installation	30
4-2. Core Diameter VS Transmission Distance	31
4-3. Wiring	32
4-4. Piping	34
4-5. Connection of the Terminal Board (TBM-11) to the Main Terminal Board	35

	Page
4-6. Connection of the Station Plug to the Exchange Jack	37
4-7. All-Call Paging Connection	39
4-8. Connection of the Talk-Back Unit	42
4-9. Power Supply Connection	43
5. Inspection	44
5-1. Inspection before Power on	44
5-2. Operation and Function Testing	44
6. Function Selection	46
7. Trouble-Shooting Guide	48
8. System Check Flow Chart	49
8-1. Fault in Exchange	50
8-2. Fault in Specific Station Only	53
8-3. Speech and Function Test	55

1. Introduction

This is the installation manual for the exchange, stations, and other components of TOA Intercom System EXES-1000.

It includes an outline of the system, an explanation of installation, cable connection, and inspection procedures, and a trouble-shooting guide. Careful study of this manual is recommended prior to installation of the system.

This manual is only intended to give the information necessary for proper installation of the system.

Prior to installation of the system, unpack the components of the system to make sure that they are in order.

2. Introduction of the EXES-1000 System

Because the EXES-1000 System is a fully electronic intercom system, it has the following features that surpass conventional mechanical systems:

1. All components of the exchange are designed according to the modular concept. This results in a sizable reduction in the number of procedures required to install the system.
2. The exchange is a wall-mounted type for space conservation. The exchange and terminal board module are designed as separate units so that installation only involves securing of the terminal board to a wall and attachment of the exchange to the terminal board,
3. The wiring for each station is an independent 4-wire system which uses a minimum number of connecting wires and means greater ease in wiring.

2-1. Exchange

2-1-1. Features

The features of the exchange of the TOA EXES-1000 Intercom System are as follows:

1. All components of the exchange are designed as plug-in modules. This results in a great increase in ease and speed of system installation.
2. Extensive incorporation of ICs in the electronic circuits of the exchange results in a

highly compact, space-saving design and quieter operation than conventional intercom system.

The system consists of only three types of basic units. This, in turn, means greater freedom in selection of an installation site.

3. Since the system is completely electronic, power consumption is kept to a minimum.

2-1-2. Specifications

The exchange of the system is available with the following specifications:

EX-110 Capacity: 32 lines max. (31 lines with paging function).

4 links

Dimensions : 19.1"(H) x 15.8"(W) x 7.0"(D)
(486mm) (400mm) (180mm)

Weight : 49 lbs max. (22 kg max.)

Exchange capacity can be increased within the given limits in units of 8 lines.

The number of lines available is reduced by 1 when the paging function is adopted.

Exchange Specifications

Ambient Temperature Range

: 32° - 122°F (0° - 50°C)

Audio Input Level : +10dBm max.

Audio Output Level : +30dBm max.
Bandwidth : 200 - 5,000Hz
Noise Level : -75dBm
Crosstalk : -60dB
Harmonic Leakage : Under -40dB
(circuit terminals)
Subscriber Impedance : 600 Ohms balanced
(input/output)
Power Consumption : 120W max.
Power Source : AC: 120V \pm 10%, 50/60HZ
(possible 110, 220 and
240V)

2-1-3. Further Details

The component modules of the exchange are grouped according to function as follows:

Common Control Section

CCU (Central Control Unit)

Speech Path Section

DLU (Duplex Link Unit)

LMU (Line Modem Unit)

The individual units will be described later in detail. The exchange also includes the Frame & Cabinet (FC-11). The Frame and Cabinet includes a power supply module (DSM-11) and terminal board module (TBM-11).

The power supply unit is self-contained and can be removed from the exchange cabinet.

The exchange operates on AC power.

The exchange is a compact, wall-mounted type.

The connectors and the frame are completely wired at the factory.

CCU (Central Control Unit)

The Central Control Unit is composed of the following three sections:

a) Central Processing Section

Controls ROM for the exchange procedure and RAM for the data in the memory, as well as performing transmission of input/output data between exchange and station.

b) Input/Output Control Section

Systematically classifies output data from Central Processing Section and then, after temporary storage, transmits the data.

It also receives dial data from station(s) for Central Processing Section.

c) Highway Switch Control Section

Directed by the Central Processing Section, connects and disconnects the time-sharing switches of station selection, link selection and signal tone selection provided by LMU and DLU.

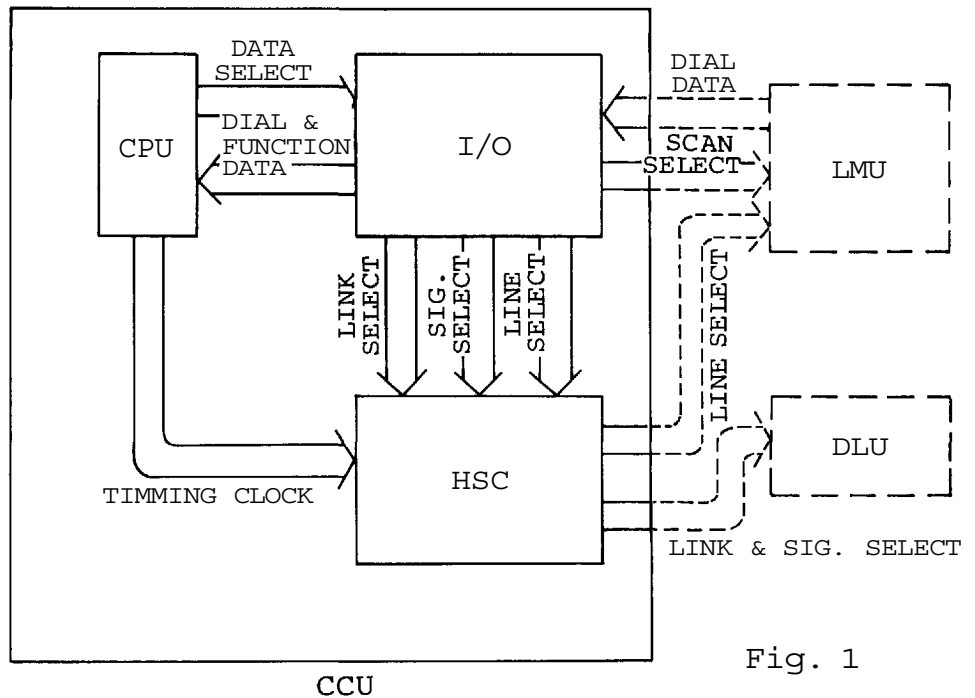
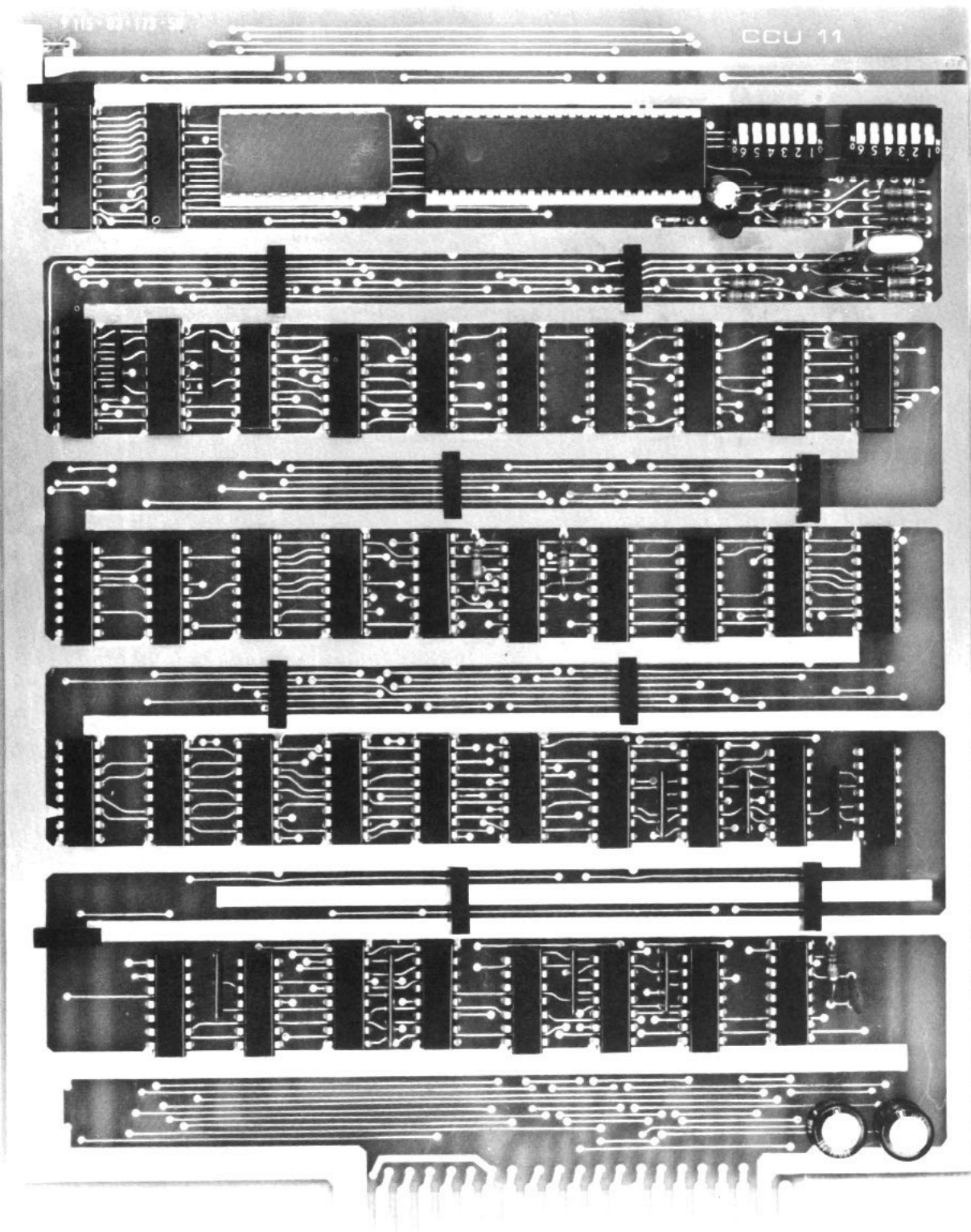

Fig. 1



CCU (Central Control Unit)

DLU (Duplex Link Unit)

The Duplex Link Unit is made up of the following two sections:

a) Duplex Link Section

Operates under CCU control to make for independent hands-free conversation between two stations. It is equipped with connection circuitry for 4 links.

b) Signal Generating and Distributing Section

Composed of a 4 tone signal generator [Call (All Call Paging), Line Busy, Hold and Privacy] and a distributor controlled by CCU which transmits the necessary signal tone to the line.

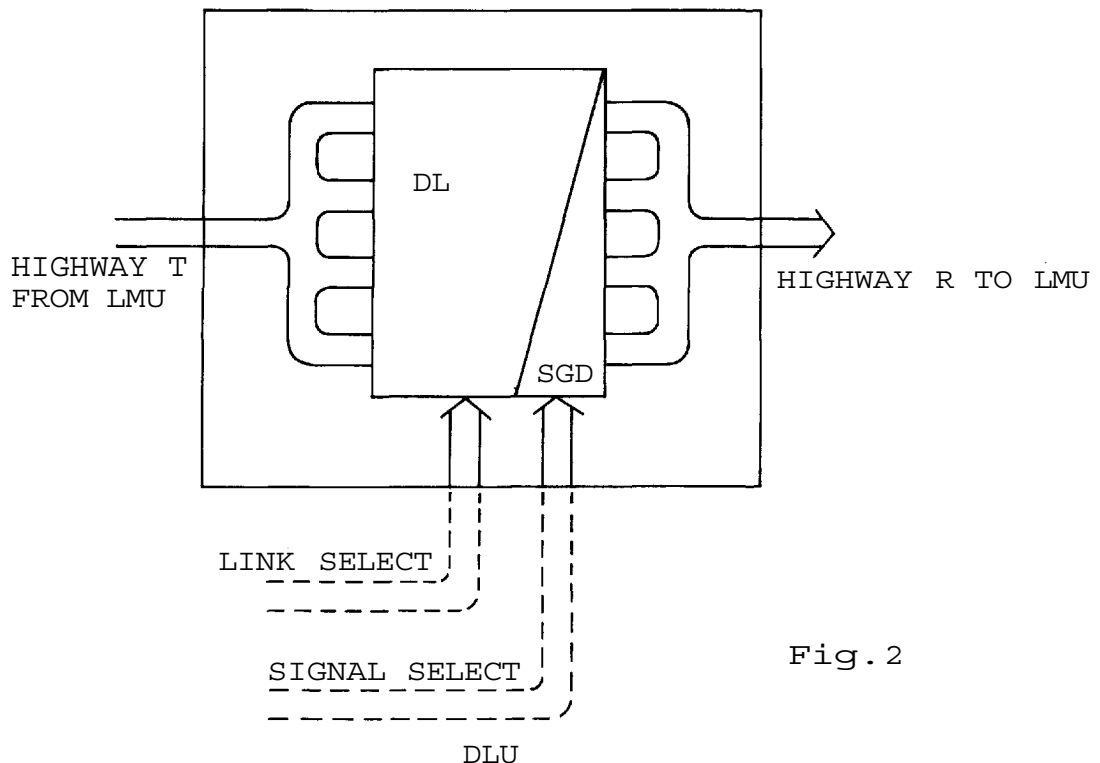
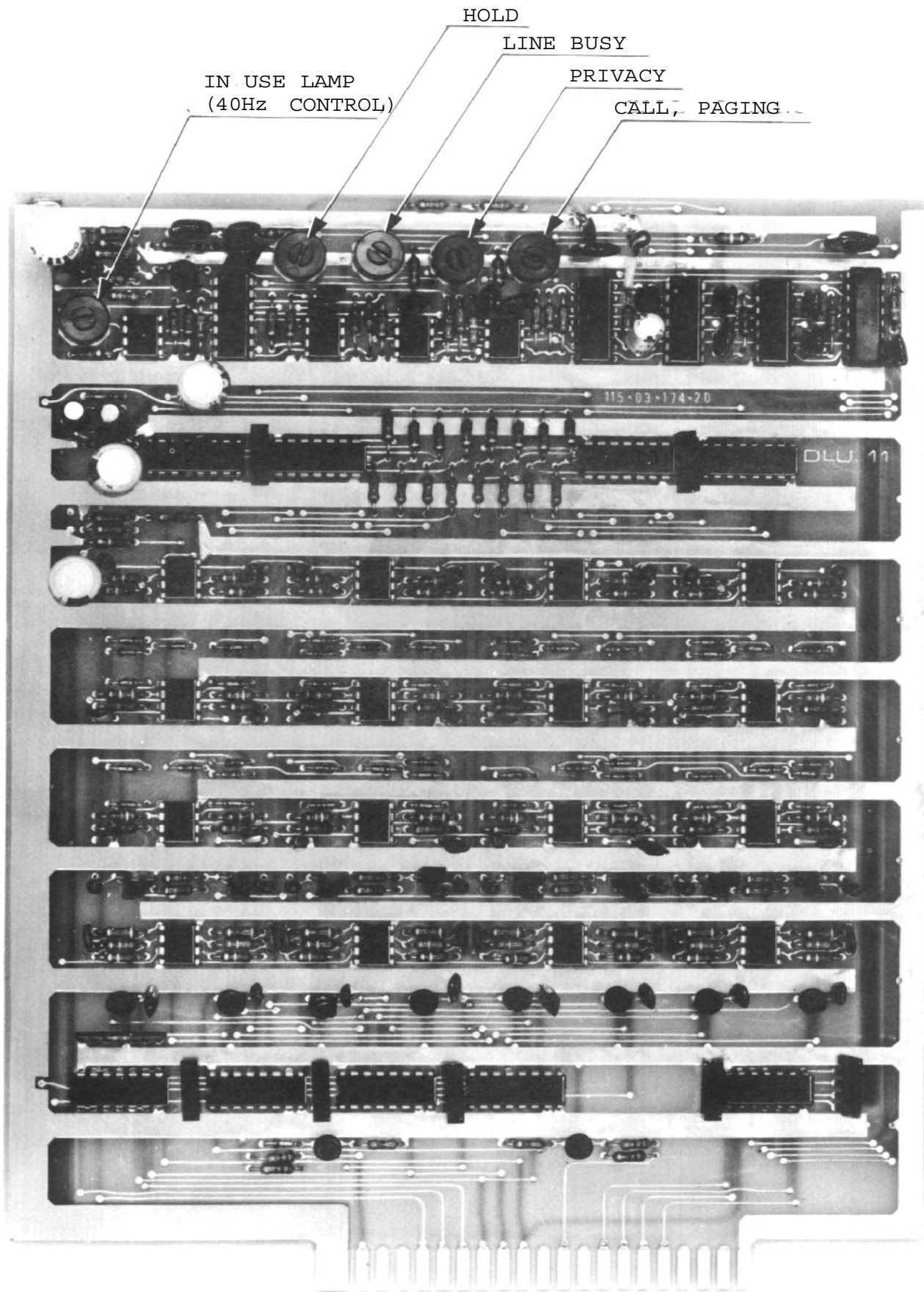

Fig. 2



IN USE LAMP
(40Hz CONTROL)

HOLD

LINE BUSY

PRIVACY

CALL, PAGING...

115-03-174-20

DLU 11

DLU (Duplex Link Unit)

LMU (Line Modem Unit)

This is an interface unit for connecting stations and exchange and performs the following two functions:

a) Line Scanner Section

Scans the station "Privacy ON/OFF" conditions and the dial data of the station and also transmits data to the CCU.

b) Line Modem Section

Modulates the audio signal from a station and transmits the modulated signal to DLU through Highway T also demodulates the signal from DLU through Highway R and transmits the demodulated signal to the station. Up to 8-station can be connected to one LMU.

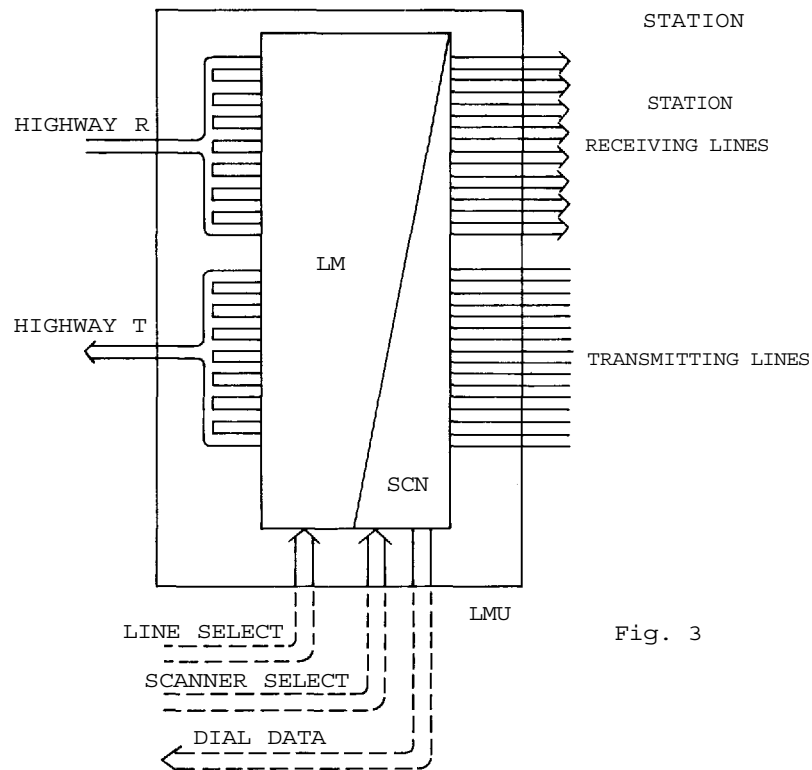
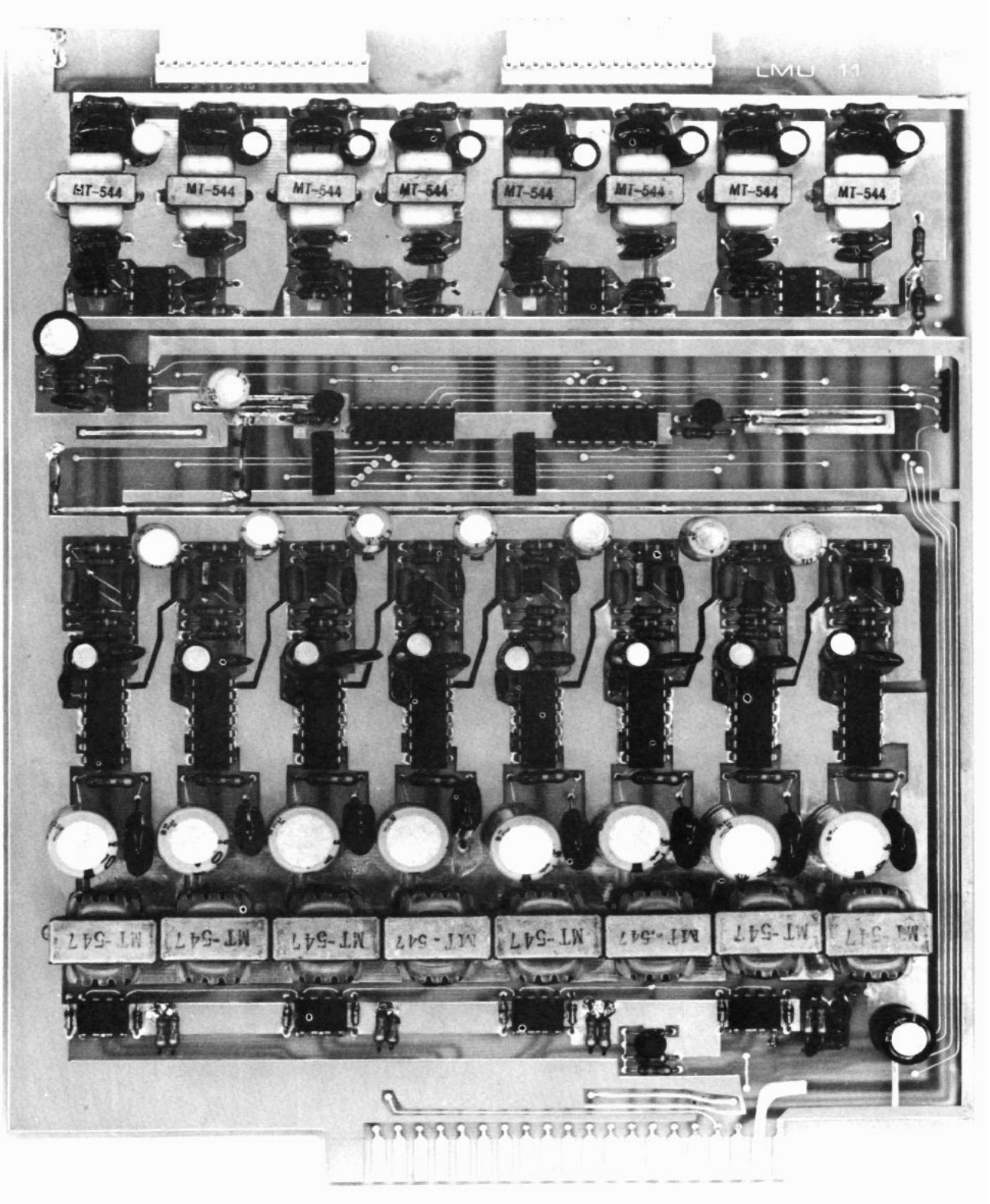

Fig. 3



LMU (Line Modem Unit)

FC (Frame and Cabinet)

The Frame and Cabinet consists of the following modules:

a) Power Supply Module (DSM-11)

The power supply is especially designed for the exchange EX-110 and is housed in the cabinet. Connections must be done as shown in the photograph.

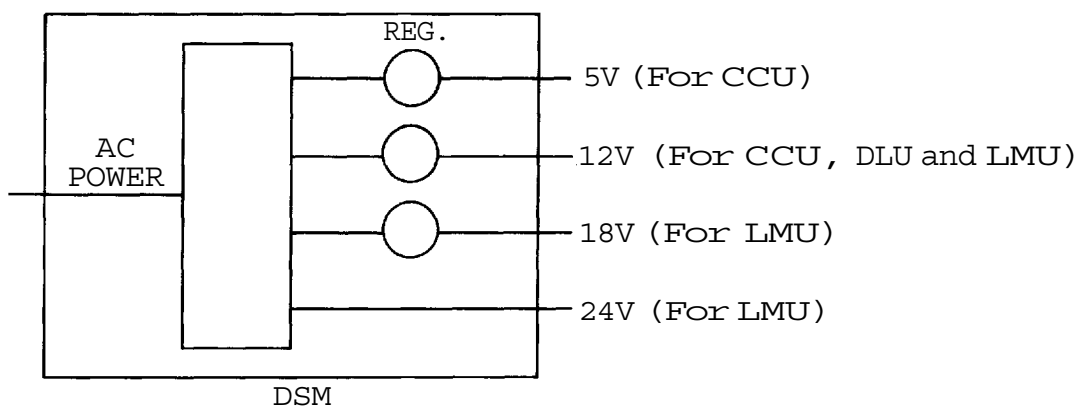

Fig. 4

b) Terminal Board Module (TBM-11)

The Terminal Board Module is designed to be separated from the exchange and is wall-mounted for space conservation. It is provided with an AC input terminal and terminals for 32 stations. The clip terminals make soldering or screws unnecessary.

Power Output Terminal

Power Supply Module (DSM-11)

Voltage Selector

Fuse

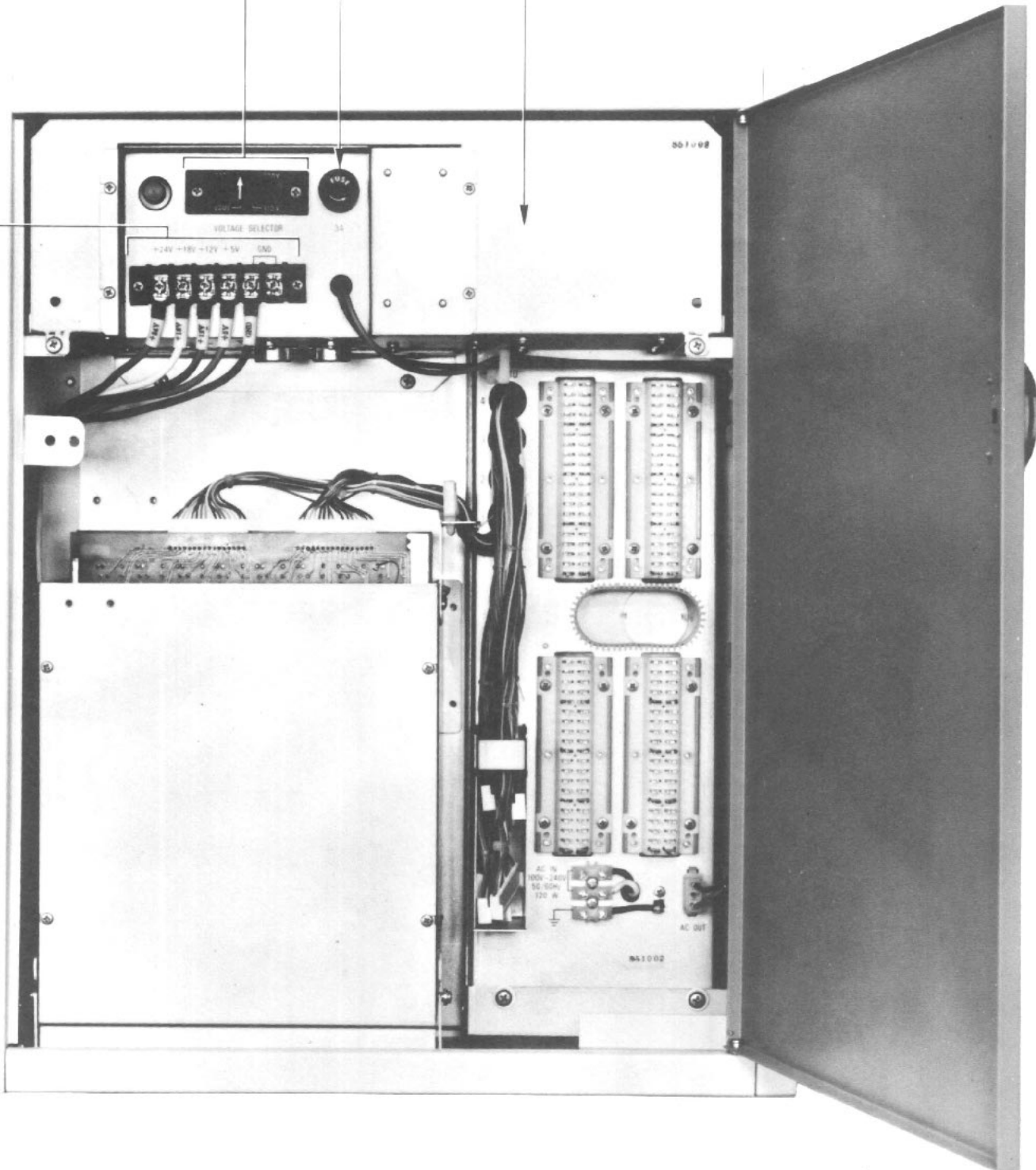

Terminals for Stations

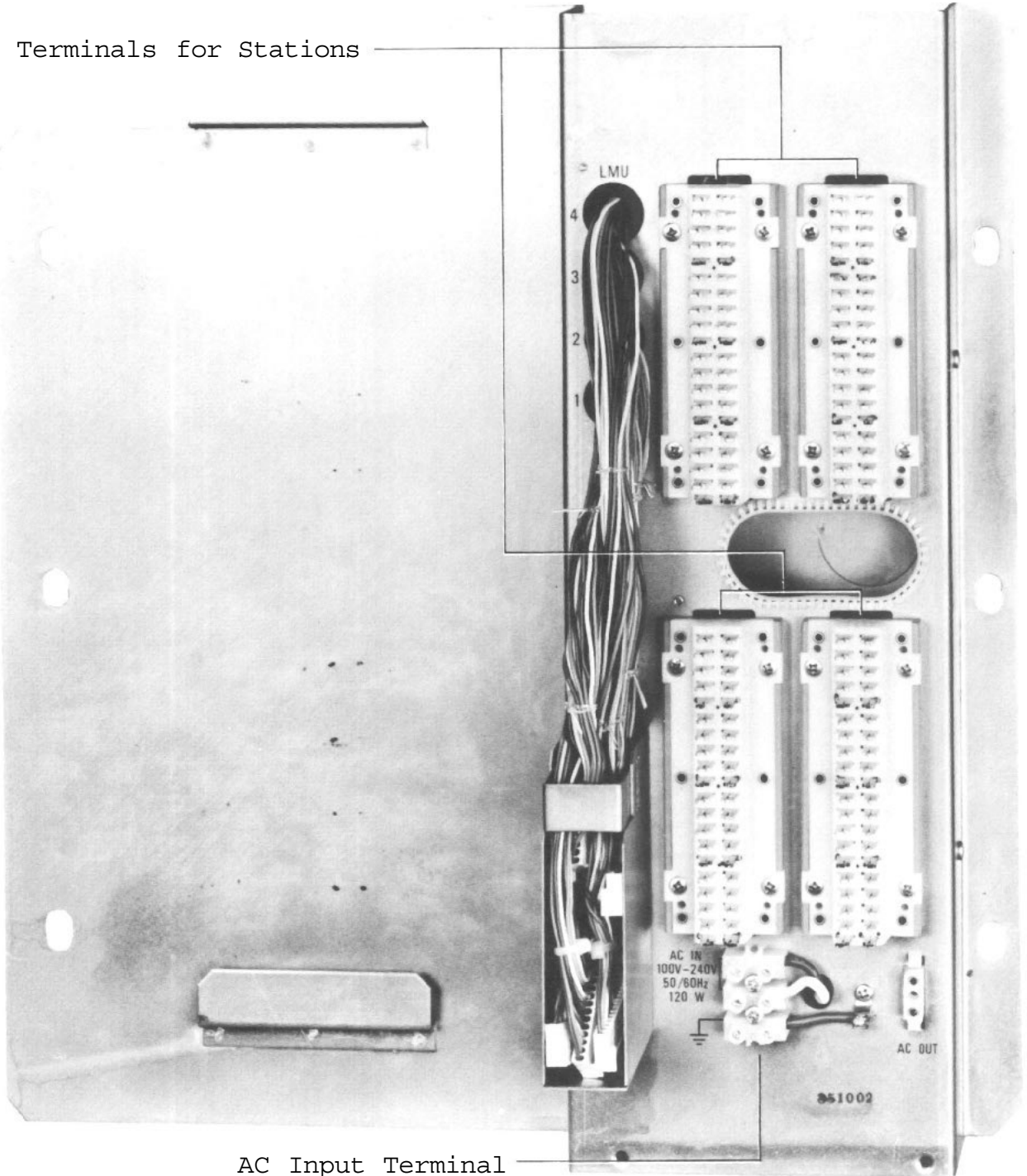

AC Input Terminal

Terminal Board Module (TBM-11)

2-1-4. Installation of each unit (CCU, DLU, LMU)

The card rack contains each unit is fixed with the fitting metal. The location of these unit is clearly marked on the card rack.

Remove the fitting metal. Pull out connection plugs from LMU's and pull a top part of the card rack toward you, then plugging in or out LMU's. No connection cable is required for CCU and DLU.

To increase the LMU, pull out the connection cable from the cable pocket to make the complete connection of the LMU which is additionally plugged in.

Finally, please double check if the LMU's are plugged in the proper location.

Station No.	10 - 17	:	LMU 1
	18 - 25	:	LMU 2
	26 - 33	:	LMU 3
	34 - 41	:	LMU 4

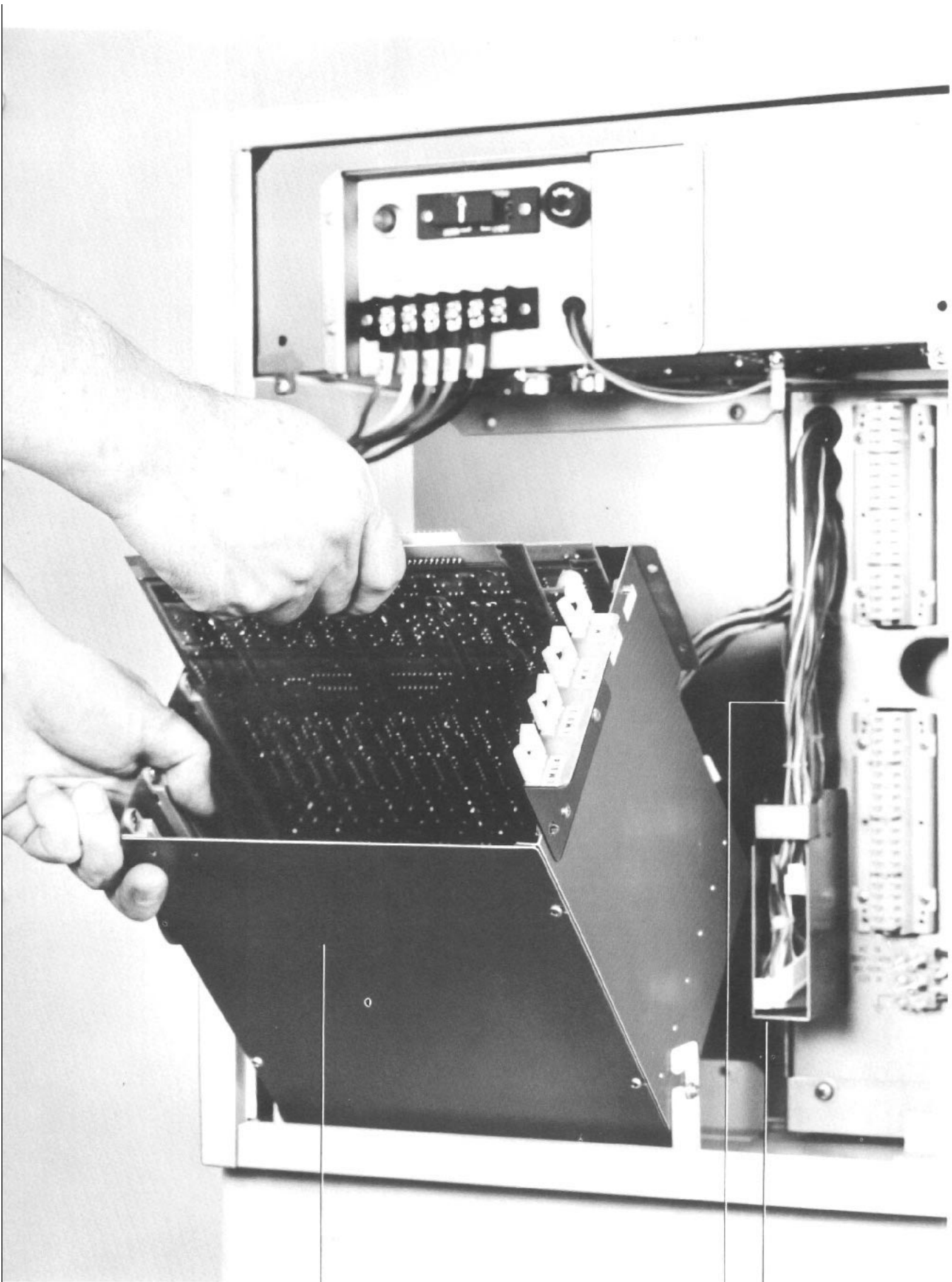

Card Rack

Cable Pocket
Connection Cables

2-2. Stations

2-2-1. Features

The stations of the Toa Intercom EXES-1000 have the following features:

1. Each station is provided with a 4-Pin plug (YC-102) for easy connection to cables.
2. Wiring from the exchange to each station is the independent 4-wire system. The fact that only 4 wires are necessary makes installation easier, and with a 4-Pin jack (YC-101 or YC-103) at the end of each cable, connection can be quickly made with a screwdriver.

There are three types of stations available the desk-top type, the flush mounting type and desk/wall type. Each type is available in 2 models, both master and substation, and these can be chosen in accordance with requirements.

2-2-2. Specifications

Stations are available in the following three models.

Model / Type / Function	Desk Type With Handset	Flush Mount Type With Handset	Desk/Wall Type Without Handset
Master Station	HFM-500	HFM-510	HFM-100
Sub Station	HFS-500	HFS-510	HFS-100

Optional Accessory: YC-100 Wall mounting panel
for HFM-100 and HFS-100.
YC-510 Back box for HFM-510
and HFS-510.

Master Station : Capable of calling any
master/sub station in the
system, and also of using
all available functions.

Sub Station : Capable of calling only its
Master Station, and also of
using the privacy, single
digit dialing and press-to-
talk functions.

Station Specifications

Ambient Temperature : +32° ~ +140°F.
(0° ~ +60°C.)

Permissible Loop Resistance: 300 ohms

Input/Output Impedance : 600 ohms
(balanced)

Loudspeaker Output : 300mW maximum

Handset Speaker Output : 100mW maximum

2-3. Accessories

2-3-1. Wall Mounting Panel (YC-100)

The Wall Mounting Panel is used for HFM-100 and HFS-100 when these stations are wall mounted (Refer to Page 28.)

2-3-2. Talk-Back Unit (TKU-11)

This unit, optional amplifier (10W max.) and speaker (Hi-Z) will allow high-volume paging and response from speaker. Conversations are conducted by using the Press-to-talk bar for press-to-talk and release-listen. The talk back speaker also operate when All-Call Paging is made from a master station.

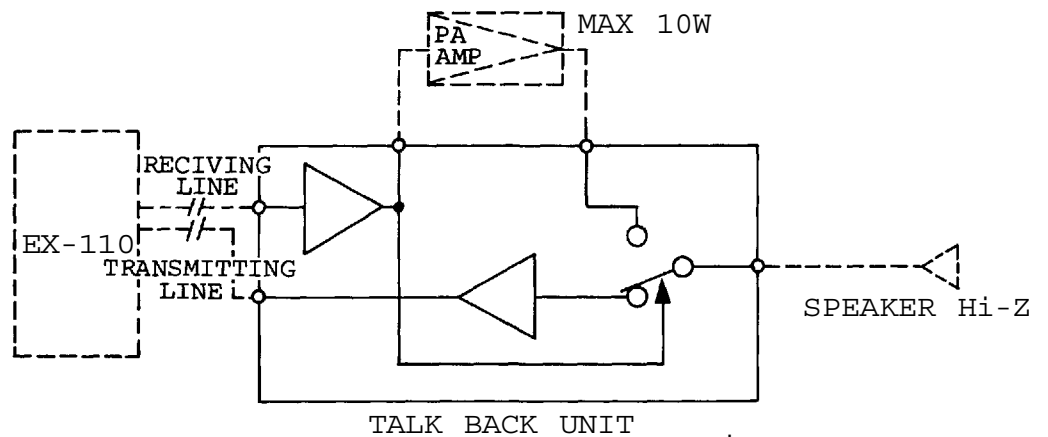
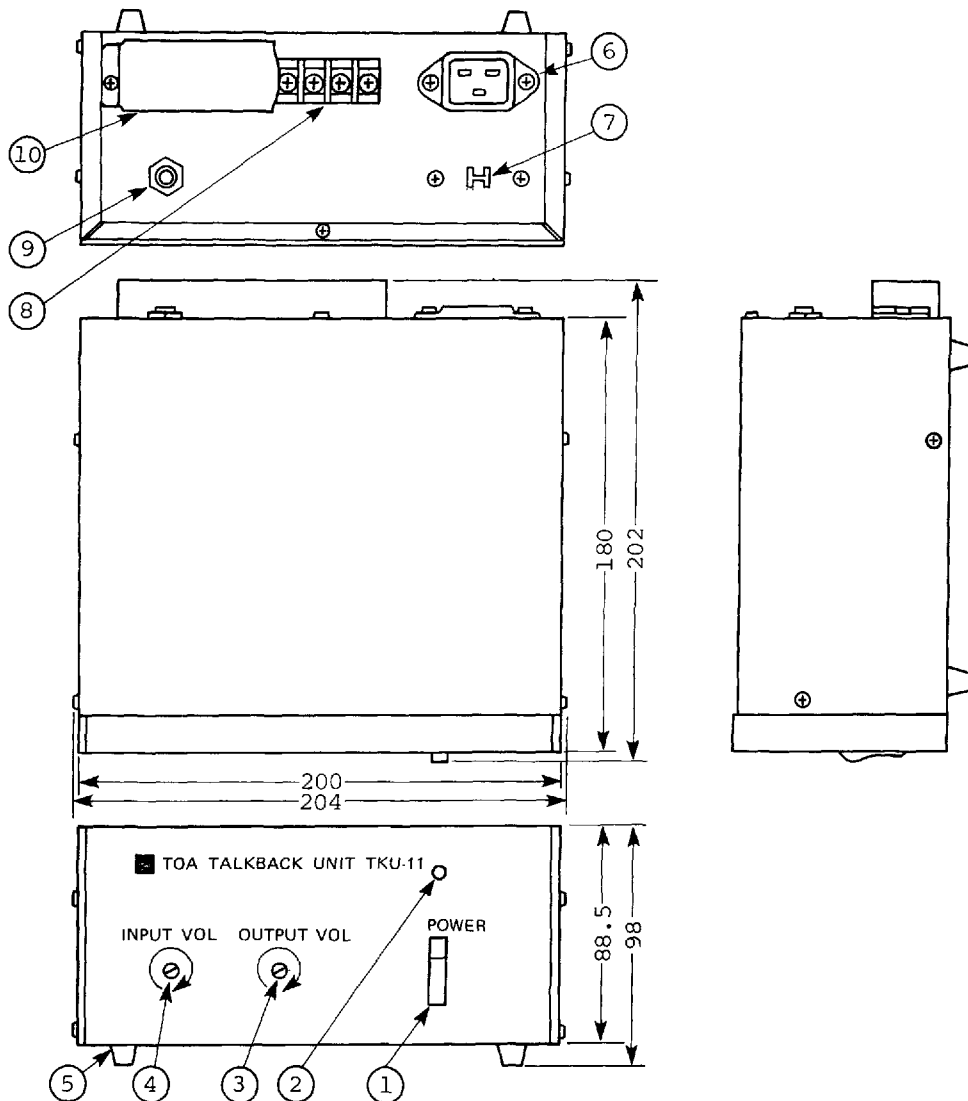

Fig. 5



1. Power Switch
2. Power Indicator
3. Output Volume Control
4. Input Volume Control
5. Rubber Foot
6. AC Inlet
7. Voltage Selector
8. 8-Pin Terminal Board
9. Output Jack
10. Terminal Board Cover

SPECIFICATIONS

Power Source: 100~120/200~240V AC

Input : Talk Back Max. 30dBm, 600Ω
Amplifier Max. 10W, Hi-z

Output : Talk Back Max. 10dBm, 600Ω
Amplifier 0dBm, 600Ω

Control : Voice Switching

Speech Control : Voice Switch or Press-To-Talk

S/N : 55dB

Dimensions : 204 x 202 x 98mm

Weight : 2kg

3. Installation of the EXES-1000 System

3-1. Exchange

Pay particular attention to the following points during installation of the exchange:

- * The layout should allow easy servicing and inspection.
- * The exchange is compact and lightweight; however it is important to ascertain the strength of the wall on which it will be placed.
- * The exchange should be grounded. When it is used in combination with other systems, for example, a PA system, the exchange should be connected to the other components for common grounding.
- * Choose a low "source noise" AC power supply for the exchange. Line noise can affect speech quality.
- * Make sure that the power cord provided adequate insulation and capacity.

This high performance exchange is compact as well as quiet, and can be easily installed almost anywhere. Areas described below, however, should be strictly avoided.

Installation Instructions

1. Put the cables through the terminal board cover and attach the terminal board cover to the terminal board.

2. Install the terminal board to wall.
3. Complete power connection, grounding and station cables to the terminals.
4. Attach exchange cabinet to terminals.
5. Attach AC connector from power supply to the terminal board.

- * An area where it will obstruct traffic, for example, an indoor hallway or near the entrance or exit of a room.
- * An area where it will be exposed to fire, heat or direct sunlight (suitable ambient temperature is +32° ~ +140°F., 0° ~ +60°C.).
- * A dusty area (where there is metal dust or dirt).
- * Near a storage place for chemicals, oil, etc.
- * An area subject to vibration.
- * Near high-voltage equipment.
- * In a strong electric field.
- * Near equipment vulnerable to the influence of an electric field.

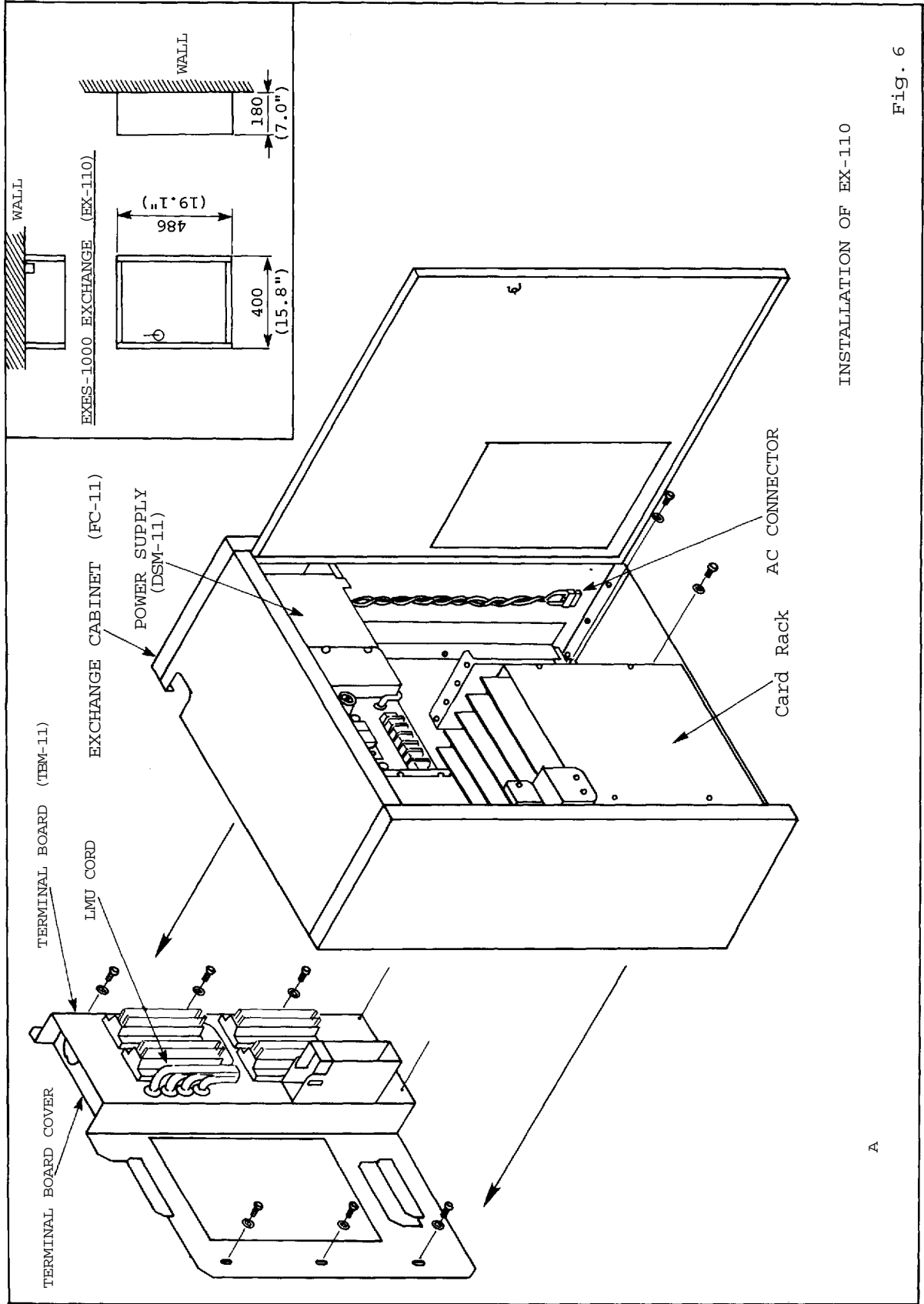

INSTALLATION OF EX-110

Fig. 6

A

REFERANCE FOR EXCHANGE MOUNTING

Use this drawing for the exchange installation especially useful for the setting of hight from floor.

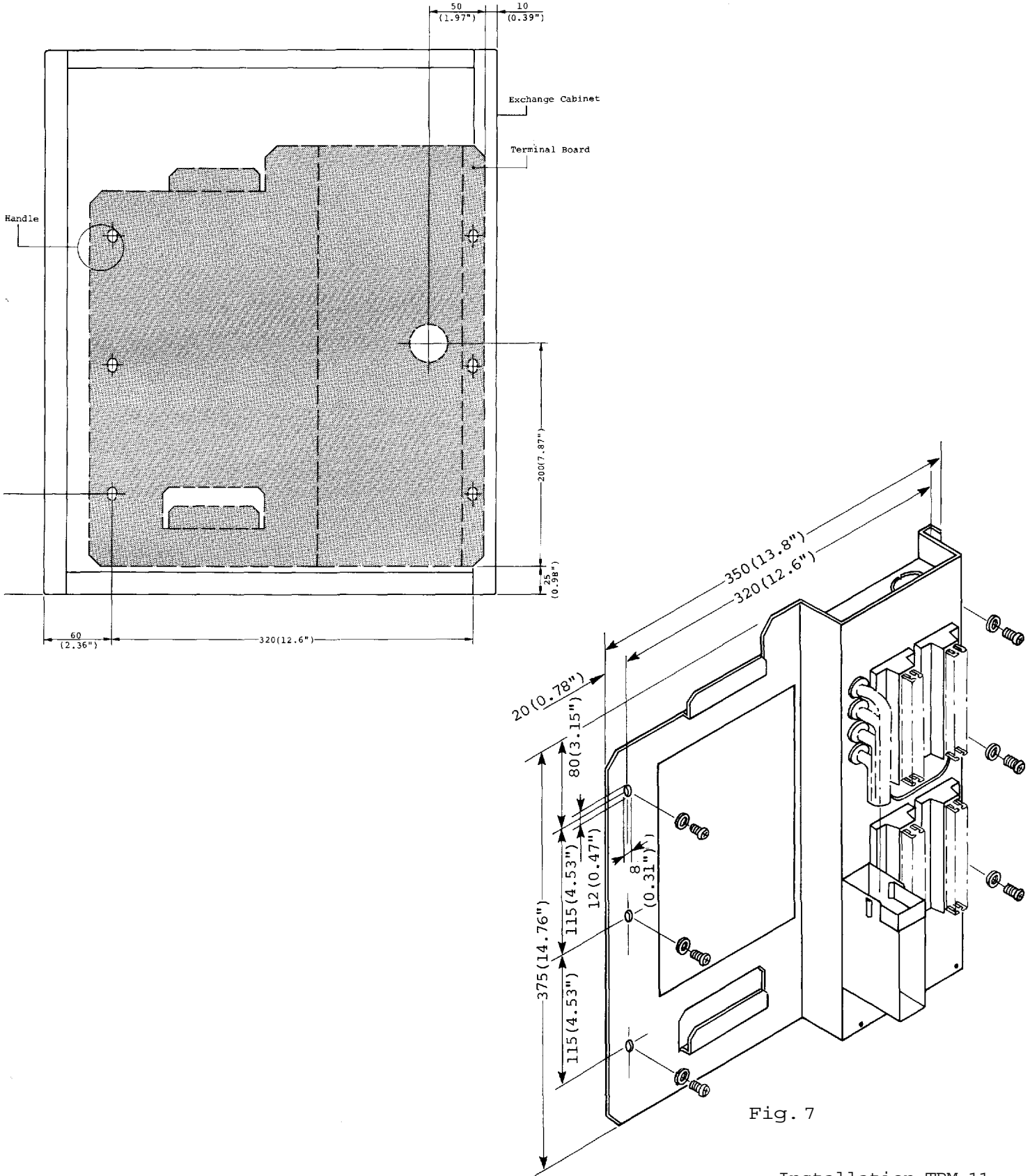

Fig. 7

3-2. Stations

Particular attention should be given to the following points during installation.

- * Choose a desk-type, flush mounting type or desk/wall type station according to the user's need.
- * If the all call paging or talk back function is adopted, precautions should be taken to ensure against feed-back due to interference between the station (microphone) and the paging or talk-back speaker; that is, they should be installed facing different directions or separated from each other as far as possible.
- * The "para-branching" operation or the connection of more than one station to one circuit is not possible.
- * Adjust the volume switch and volume control on the station for comfortable speaker output level or for avoiding the trouble caused by acoustical conditions such as reverberation and echo.

Stations are compact for easy installation almost anywhere. However, areas described below should be strictly avoided.

- * An area where it can be exposed to fire, heat or direct sunlight (suitable ambient temperature is +32° ~ +122°F., 0°C ~ +50°C.) .
- * A dusty area (where there is metal dust or dirt).

- * Near a storage place for chemicals, oil, etc.
- * An area subject to vibration.
- * Near high-voltage equipment.
- * In a strong electric field.
- * SCR type light dimmers.

3-3. Accessories

a) YC-100

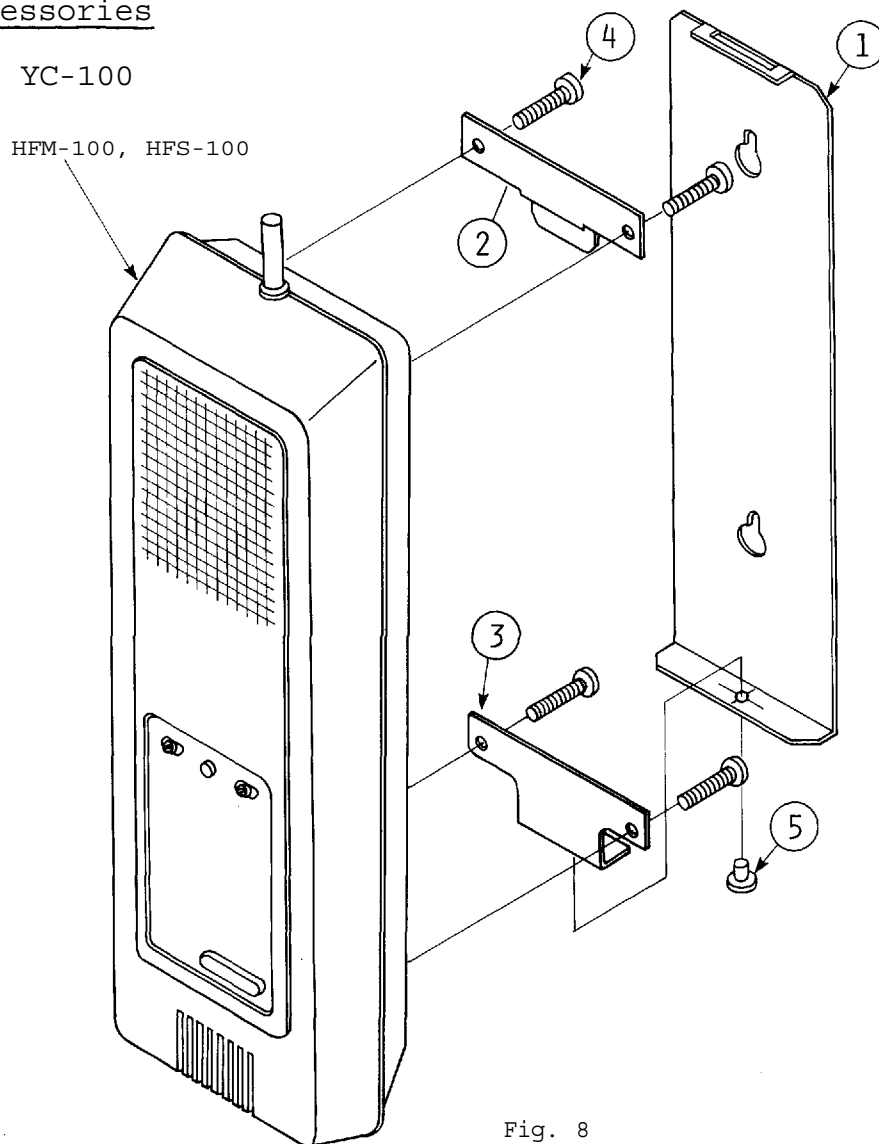

Fig. 8

First, install panel (1) on wall. Install panel (2) and (3) on HFM/S-100 with screws (4), then fix the unit on the panel (1) with a screw (5).

b) TKU-11

The talk-back unit is to be installed with an optional amplifier (10W max.) in the place where the talk-back function is desired.

The speaker is to be a Hi-Z trumpet speaker installed on the ceiling or wall. The optimum installation site for the speaker is approximately 2m from speaking position. The talk-back unit should be placed by the optional amplifier. The speaker should be installed as close to the talk-back unit as possible.

Be sure to use shielded cable or twisted cable for the speaker wires to prevent the effects caused by high-voltage cables, electromagnetic induction and high-frequency waves.

4. Cable Installation and Connection

4-1. Cable Installation

4-1-1. Wire type, number of wire pairs and number of individual wires are to be determined for individual sections of the wiring system according to the guidelines set down below.

- * 4-wire telephone cables are to be used for wiring between the intermediate and indoor boards.
- * As a rule, private branch cables are to be for wiring between indoor terminal boards, intermediate terminal boards, main terminal boards, etc.
- * Outdoor wires should be used where wiring passes through inaccessible areas such as in ceilings or under floors. Indoor wires may also be used, however, in cases where there is no risk of deterioration due to exposure to heat, etc.
- * The number of cable pairs laid should be determined considering the possibility of future expansion of the system.

The following chart is provided to give an actual example of the wiring plan within an installed system.

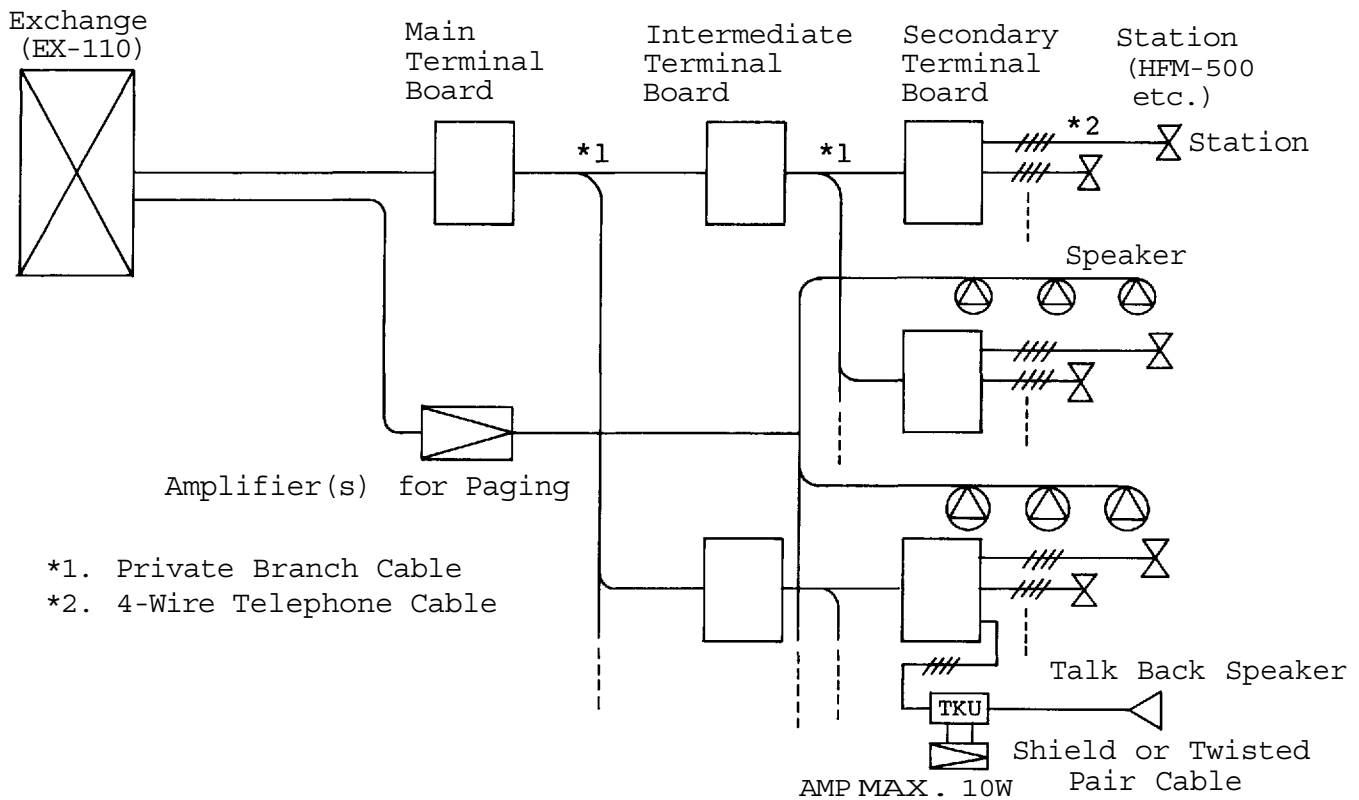

Fig. 9

Note: There is a limit to the diameter of cables that can be used to connect the terminal board TBM-11 and the main terminal board, and this limit must be taken into consideration when planning wiring of the system. The diameter must be between 0.016" (0.41mm) and 0.031" (0.79mm).

4-2. Core Diameter Versus Transmission Distance

The diameter of the cable to be used should be determined so that the set limits for speech attenu-

ation (3dB maximum for transmission from the exchange to the station and the DC resistance (DC loop resistance: Less than 300 ohms) are met.

Speech Attenuation, DC Loop Resistance and Service Distance as Functions of Core Diameter

AWG No. (Solid)	Core Diameter mils. (mm)	Speech Attenuation dB per 1000ft (dB per 1 km)	DC Loop Resistance Ω per 1000ft (Ω per 1 km)	Service Distance ft (km)
22	25.3 (0.64)	0.411 (1.35)	35.1 (115)	7,300 (2.2)
24	20.1 (0.51)	0.521 (1.71)	54.5 (179)	5,500 (1.1)

4-3. Wiring

General Information

- * Wiring should be done independent of public telephone lines.
- * Wiring conduit is often installed underground or embedded in building structures such as walls and floors, so care must be taken to draw up a wiring plan that has ample reserve for future extension of the system and that can be adapted to future remodelling or expansion of the building it is housed in. Wiring or expansion of the building it is housed in. Wiring systems must be planned with ample wires and conduit and with provision for additions to the system.

Spacing

Since the working voltage of this system is low and the current passing through it is small, there is no major safety problem involved in the wiring.

However, since interference due to contact with other indoor wiring can cause wire damage, leakage, and other problems, spacing should be given close consideration when the small-current wiring of this system is laid close to other indoor wiring, particularly AC wiring.

The following chart lists spacing standards to be followed in respect to typical causes of interference.

Cause of Interference	Minimum spacing acceptable without extra protection	Remarks
Heating Pipe	6" (15)	This minimum spacing requirement should be observed, since intercom cable is vulnerable to heat.
Water Pipe	4" (10)	
Radio transmitting coaxial cables (CB and other). Telephone wire.	12" (30)	More spacing is required where there is a risk of induction.
Radio/TV Antenna coaxial cables & twin lead. Ground cable.		
Protected Heating and Cooling Pipes.	4" (10)	

4-4. Piping

- * Where wiring is to be passed through a wall or the like, it should be protected by a hard PVC or metal tube.
- * If the number of connecting wires between an indoor terminal board and a station is small and the station's site is fixed so that it will not be moved frequently, install a box at that site and pull wiring through a metal or hard PVC tube as required by job or ordinance.
- * Use a floor duct if the number of connecting wires is large and the stations are likely to be moved frequently.
- * Station wiring which must be laid-across open areas of floor should be protected by plastic or metal shields. (See drawing below)

EXAMPLE:

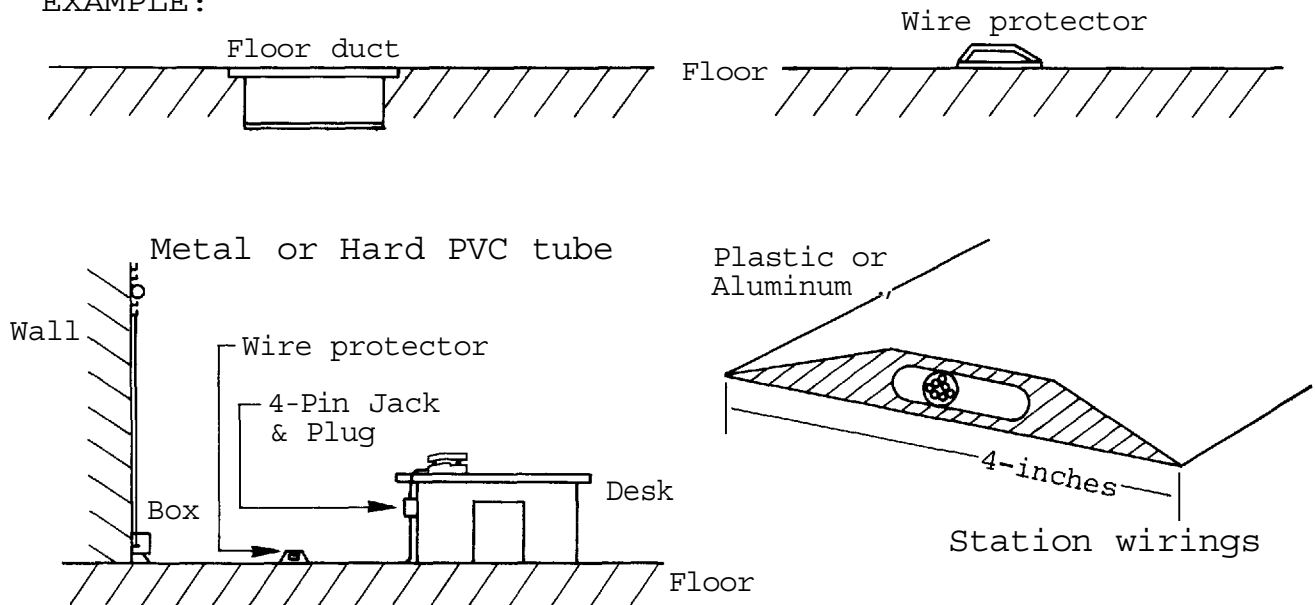

Fig. 10

4-5. Connection of the Terminal Board (TBM-11) to the Main Terminal Board

Route cables from the main terminal board to the terminal board (TBM-11) and connect to the individual clip terminals using clipping tool C.

Connect the individual cables to the clip terminals following the terminal wiring diagram attached to the door.

Connect cables to the clip terminals according to the following procedure:

- * Remove the cable outside insulation tubing so that the wires are showing. (Cutting through insulation of individual cable wires should be avoided.)
The length of cable insulation to be removed should be 1.5 times the length of the clip terminal.
- * Leave the insulation on the cable wires and attach cable to the upper part of the clip terminal.
Then, holding the excess length of wire in hand, pull it toward the access side and push it down from above the clip terminal using clipping tool C.
- * The cable connection is complete when the excess wire is cut off.

Hook the connecting wire around the tab at the top of the terminal and then push it in using the clipping tool.

Connection of the Station Line to the Clip Terminal of the Terminal Board (TBM-11)

Note:

Connect the individual cables in order, starting with the top terminal.

When using the clipping tool, be sure that the cutting edge is on the side the wire to be cut off.

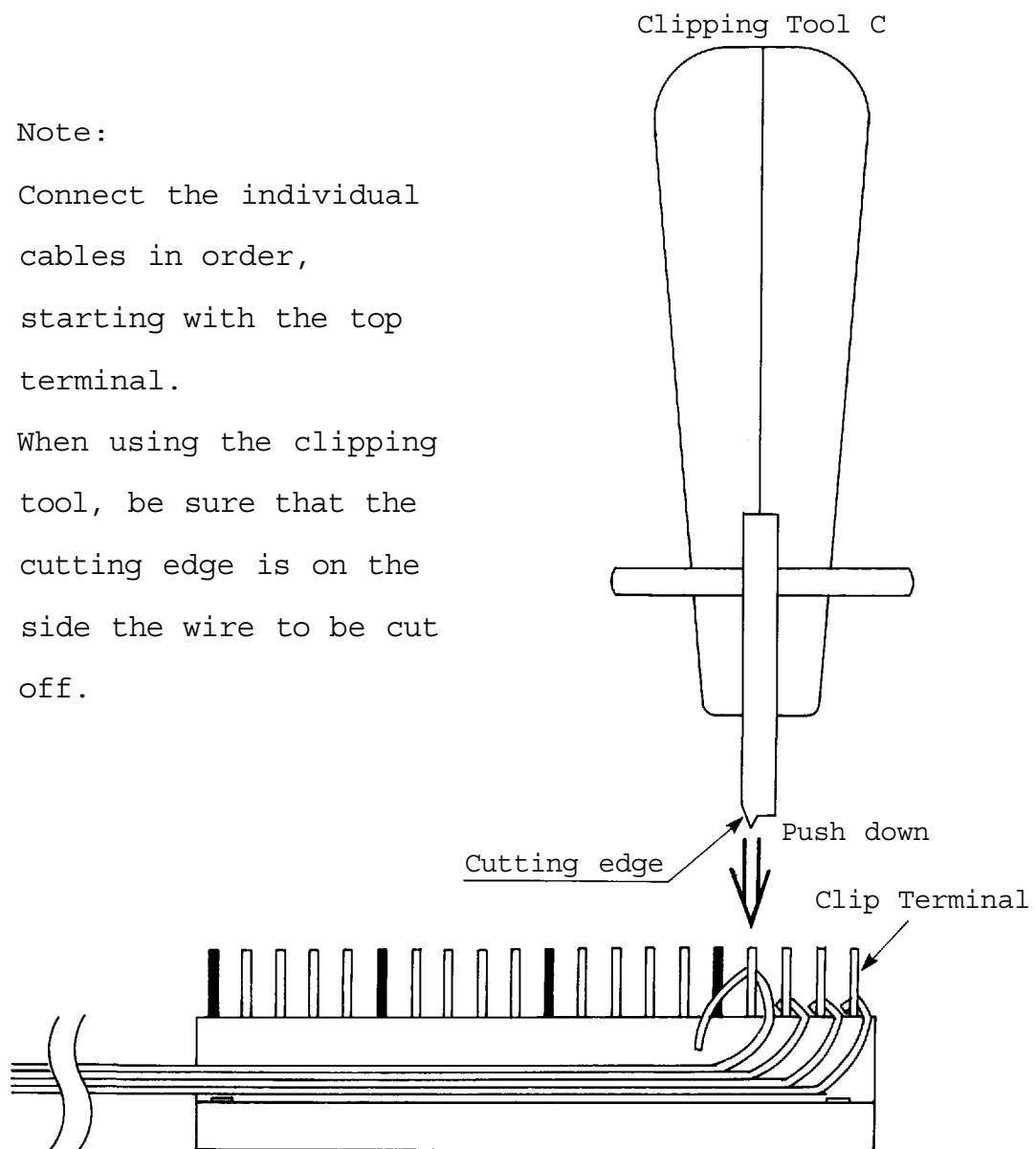
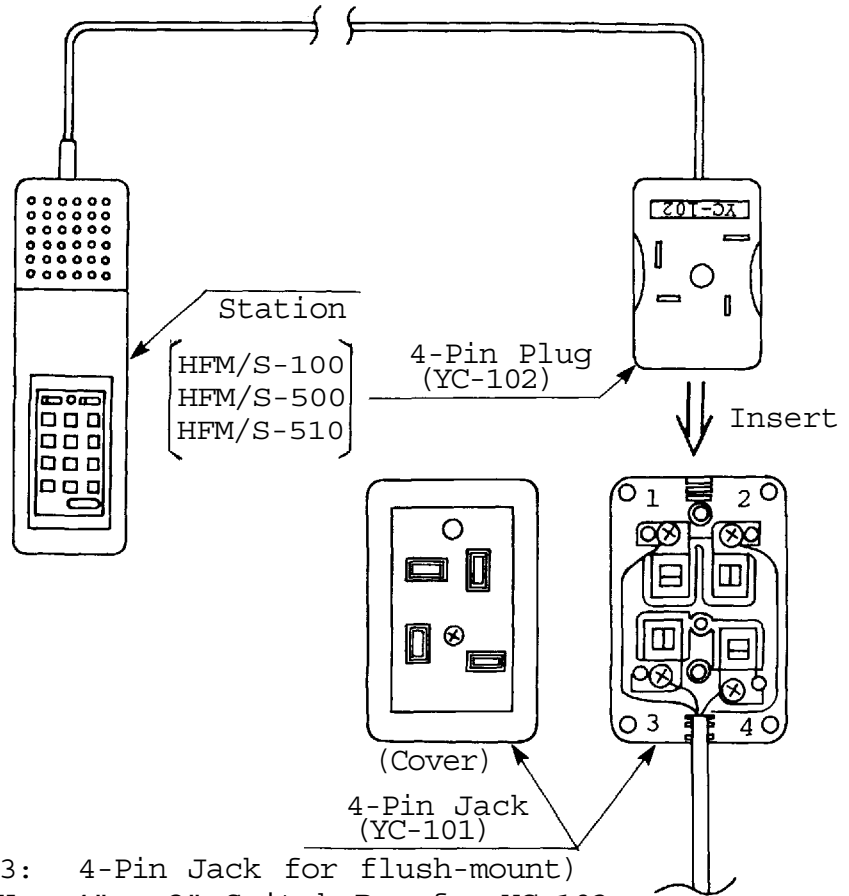

Fig. 11 Clip Terminal (Side View)

4-6 . Connection of the Station Plug to the Exchange Jack

(YC-103: 4-Pin Jack for flush-mount)

NOTE: Use 4" x 2" Switch-Box for YC-103



(YC-103: 4-Pin Jack for flush-mount)

NOTE: Use 4" x 2" Switch-Box for YC-103..

1 } Receiving Lines
 2 } (not Polarity Specified)

3 } Transmitting Lines
 4 } (not Polarity Specified)

(Viewed from the station side)

Terminal Board (TBM-11) Clip Terminals

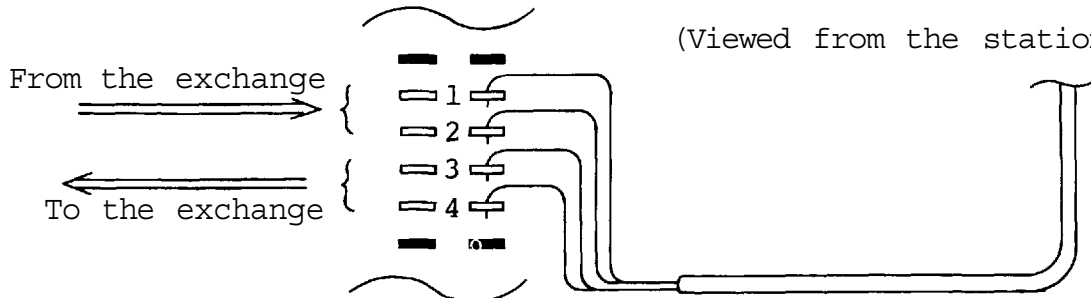
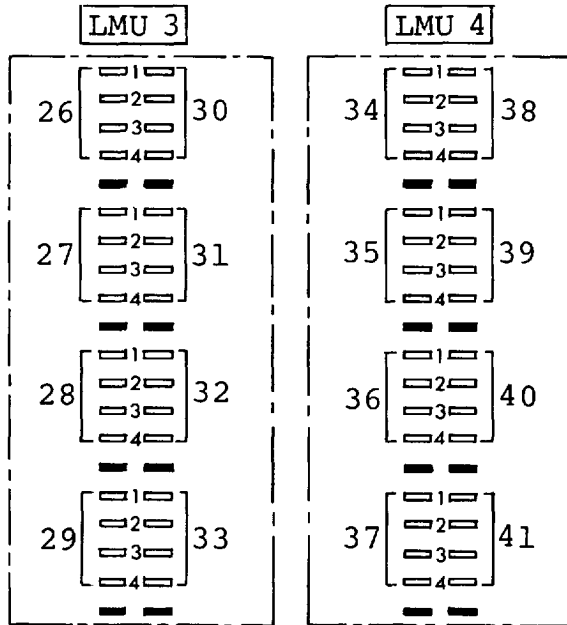
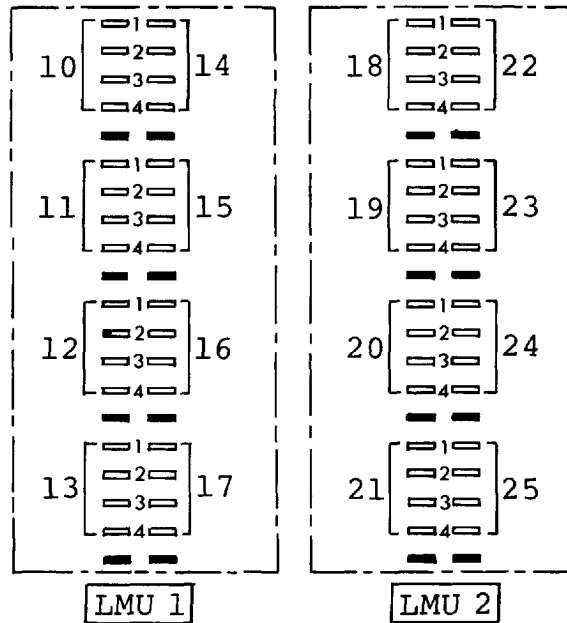
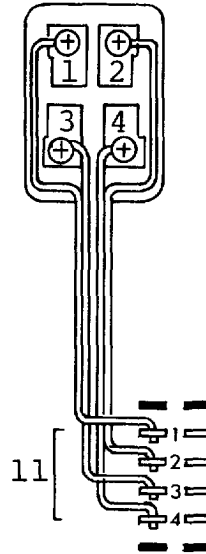

Fig. 12

EX-110 TERMINAL BOARD



CONNECTIONS
STATION
STATION #11
TERMINAL



PAGING

TALKBACK

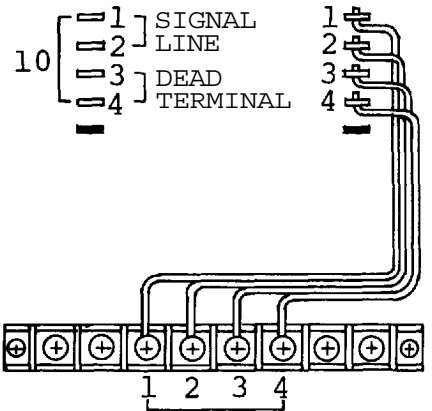

TKU-11 TERMINAL

4-7. All Call Paging Connection

Use No. 10 on the terminal for output when using the paging function.

Connection of the optional amplifier is illustrated below.

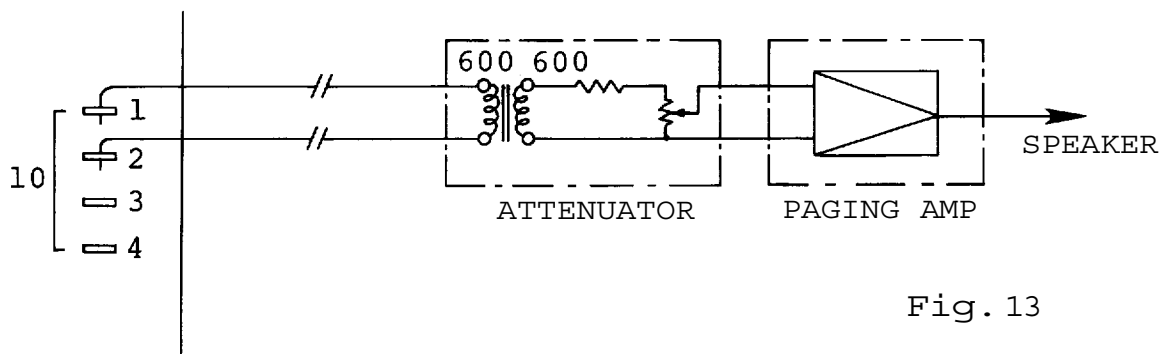

Fig. 13

Since the output power from station No. 10 is considerably higher than a regular amplifier's input (AUX.) capacity, an attenuator is required.

Note: When paging function is used, station No. 10 cannot function as a station.

Signal Line

Impedance : 600 ohms, balanced

Output level: +30 dBm (max.)

All call paging can be heard through the external PA speaker as well as through the speakers built in the handsets, except when the line is being used.

All Line Modem Units (from 1 to 4) are factory set so that paging through the speakers in the station is impossible. All LMU-11s are equipped with the

same specifications; when speaker paging from the station is desired, follow these procedures:

- 1) Cut jumper A on all LMU-11s.
- 2) Excluding the LMU-11 for Nos. 10 to 17 (installation position LMU-1), cut jumper B of the remaining LMU-11s.

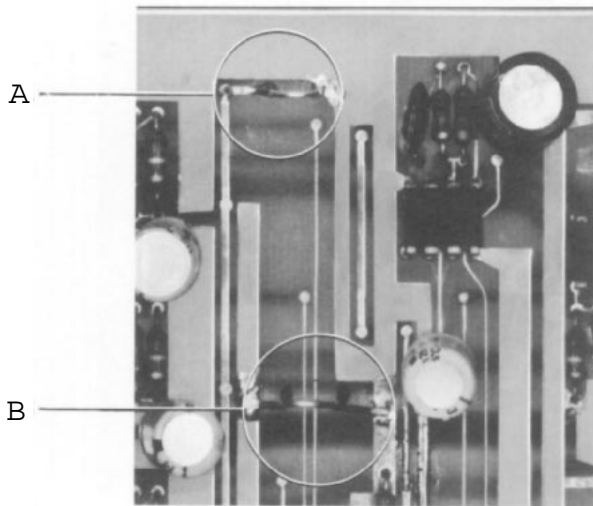

DIP SW AND JUMPER ARRANGEMENT

CCU -11		WITH PAGING		WITHOUT PAGING	
		DIP SW B-6 ON		DIP SW B-6 OFF	
LMU-11		A	B	A	B
	1	X	O	O	X
	2	X	X	X	X
	3	X	X	X	X
	4	X	X	X	X

(1)

O : JUMPER ON
X : JUMPER OFF

When a designated station speaker (for example, No. 13) is not required to be called by All Call paging, remove the capacitor as shown in the illustration below in addition to the above mentioned procedure.

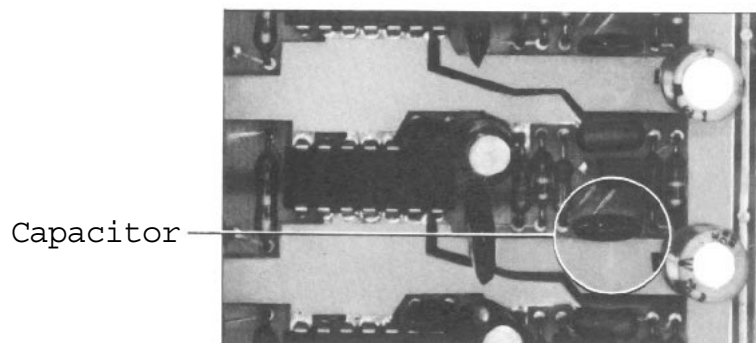

(2)

LMU11 N013

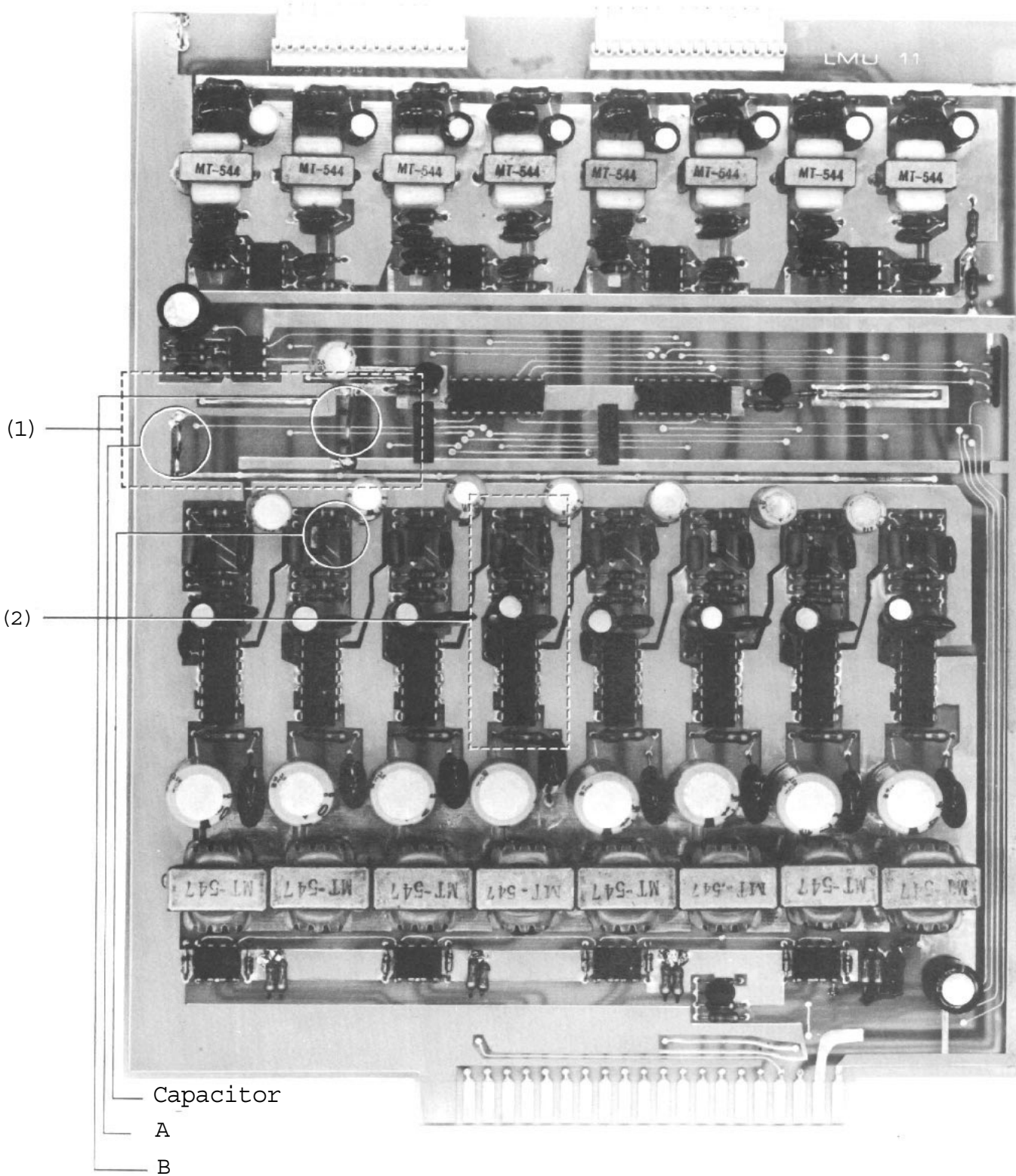

LMU-11

4-8. Connection of the Talk-Back Unit

Connection of the talk-back unit is shown below.

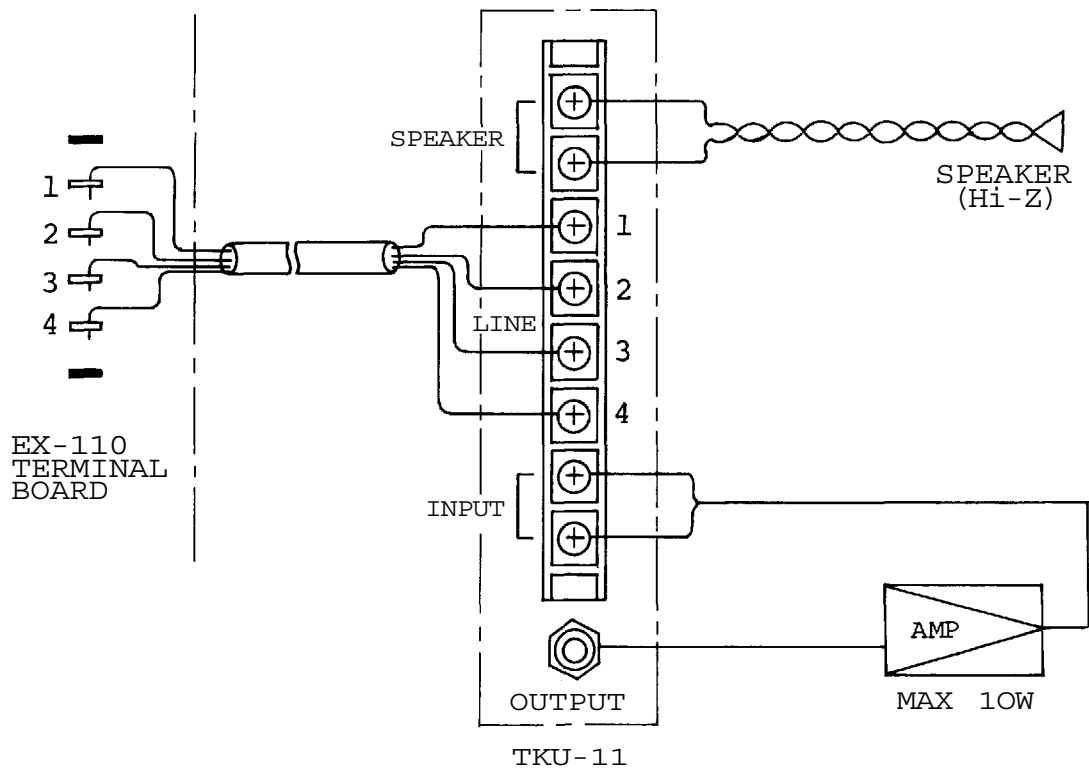

Fig. 14

When the talk-back speaker is used as a microphone, sound clearness and microphone sensitivity vary according to the ambient noise level and installation position. The sensitivity of the talk-back speaker's microphone can be adjusted by the input volume control on the front of the TKU-11.

Adjustment is necessary after installation.

4-9. Power Supply Connection

A 3P terminal for power supply is provided on the terminal board of EX-110.

When a standard AC outlet without special power cable works is used, the optional YA-308 or YA-309 power cable can be utilized.

A power supply for the exchange which is not affected by power failures is recommended.

Be sure to ground the exchange.

After completion of the power supply connection, use the power connector for switching on and off as power switch is not equipped with the exchange.

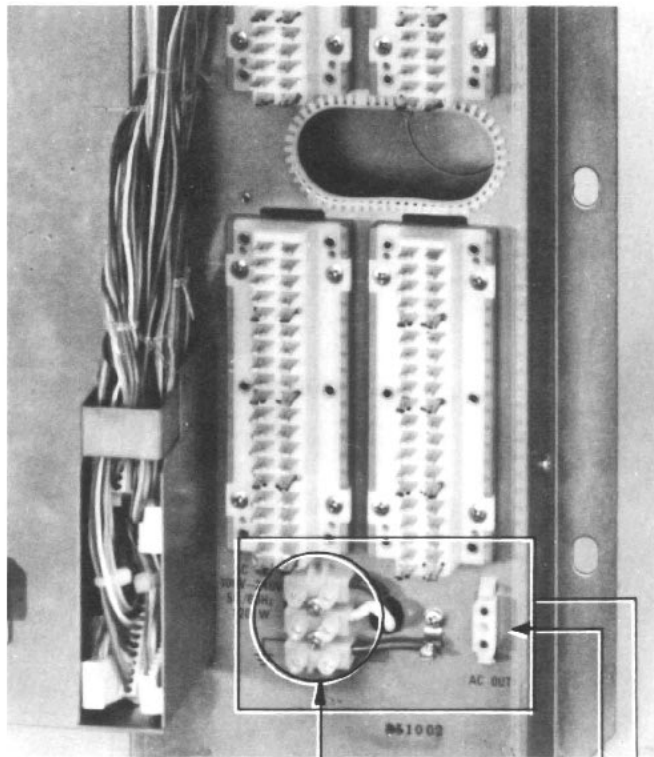

AC Input Terminal
Power Connector
Power Supply Connection

Power Supply Cables

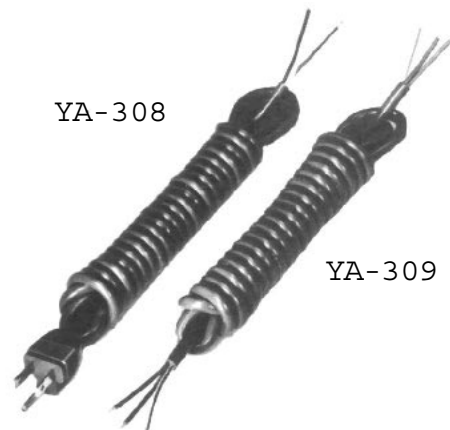

YA-308

YA-309

5. Inspection

5-1. Inspection before Power on

- * Before supplying AC power, check if the power connections are completed and the fuse is in place. Also make sure that the voltage selector is set correctly. All the modules should be placed and secured. Check if the CPU and ROM on the CCU-11 are securely in the sockets. Insert the LMU connection cord (LMU 1 - LMU 4) of the terminal board into the LMU properly. Make sure that the connections of exchange and stations are completed.
- * Supply AC power.
- * AC indicator lamp on the front of the power supply module should be on. If not, electricity is not supplied. Disconnect AC power and check the connections and fuse.
- * Handle plug-in units with care; plug-in units incorporate CMOS. After the exchange is powered do not attempt to disconnect the plug-in unit.

5-2. Operation and Function Testing

Pick out a convenient station and call all the stations connected on the exchange and check the volume and static.

Volume of calling tone and talking tone can be adjusted by the volume control on the back of the station. Use a small screwdriver; turn clockwise

for maximum, and counterclockwise for minimum volume. There is also a volume switch on the keyboard of the station for the user. Paging volume should be adjusted to eliminate howling, using a station closest to the paging speaker. Adjust the input volume control of the talk-back unit for microphone sensitivity. While testing for operation, check all the functions listed in the operational instructions.

6. Function Selection

The DIP switches on the CCU-11 allow selection of the following functions:

- a. Secretary Transfer
- b. Master/Substation
- c. Call Holding/Call Transfer
- d. All Call Paging and Response

When the CCU-11 board connector is up, the two DIP switch sections are located at the bottom.

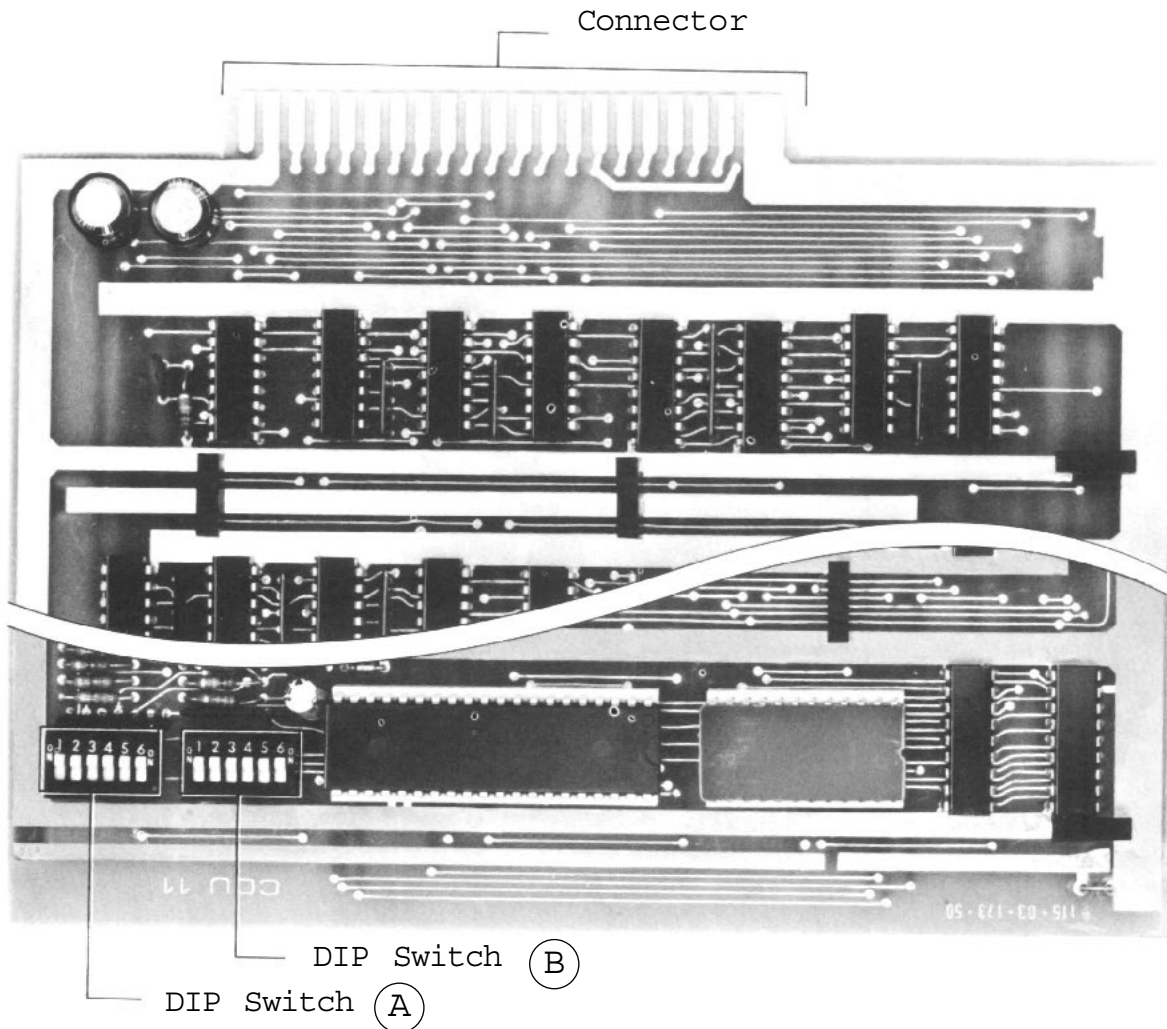

CCU-11

SW (A) for selection of Master/Substation:

<u>SW No.</u>	<u>Master/Substation Combination</u>
1	No. 13 ~ No. 14
2	No. 15 ~ No. 16
3	No. 21 ~ No. 22
4	No. 23 ~ No. 24
5	No. 29 ~ No. 30
6	No. 31 ~ No. 32

Turn on the corresponding switch for Master/Substation combination. For example, SW No. 1 for No. 13 - No. 14 Master/Substation combination.

SW (B) 1 ~ 4 for selection of Secretary Transfer.

5 for Call Holding/Call Transfer.

6 for All Call Paging.

<u>SW No.</u>	<u>Executive</u>	<u>Secretary</u>
1	No. 11 ~	No. 12
2	No. 19 ~	No. 20
3	No. 27 ~	No. 28
4	No. 35 ~	No. 36

Call Holding/Call Transfer and All Call Paging are possible for all master stations.

Each function is adopted when dip switch is ON.

7. TROUBLE SHOOTING GUIDE

Repairing of the EXES-1000 system is basically done by replacing defective units with good ones. The system's faults in an installation can be divided into the following categories.

1. Faults in an exchange
2. Faults in a station
3. Cable faults

To make system repairing easier, find which category is involved, then refer to the chart below for assistance in fault finding.

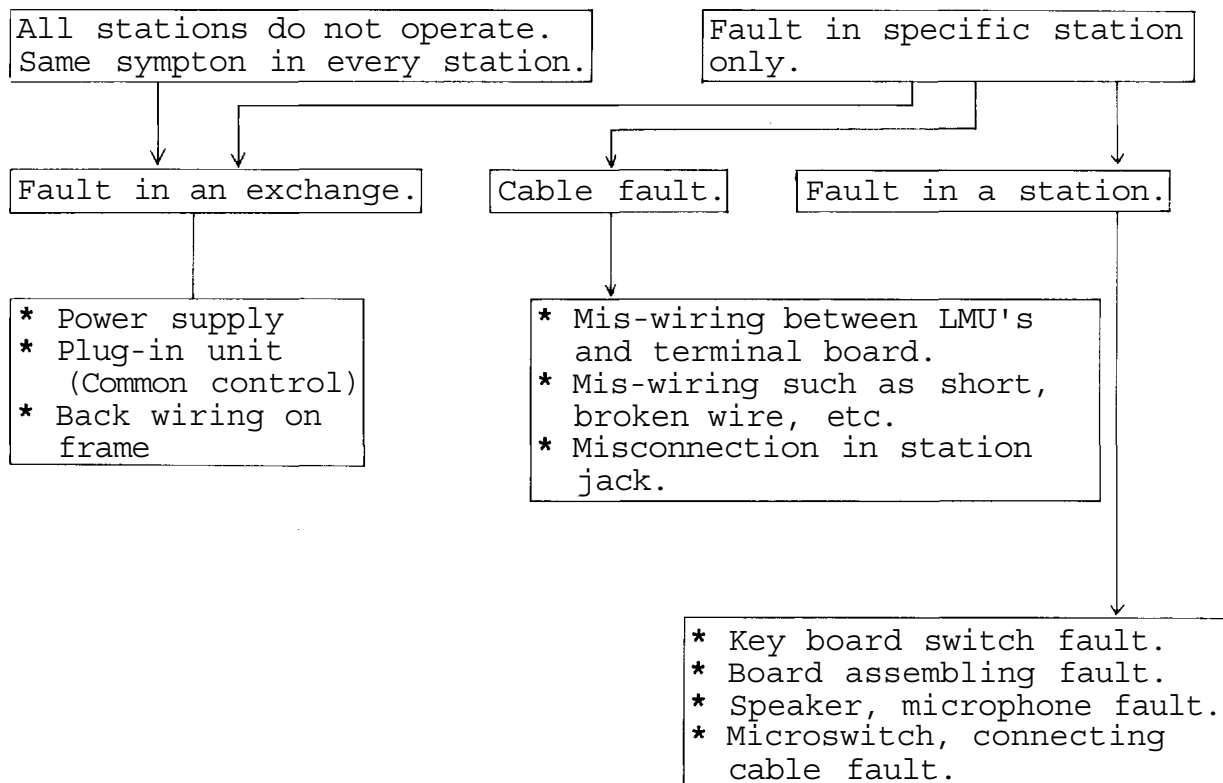

8. EXES-1000 System Check Flow Chart

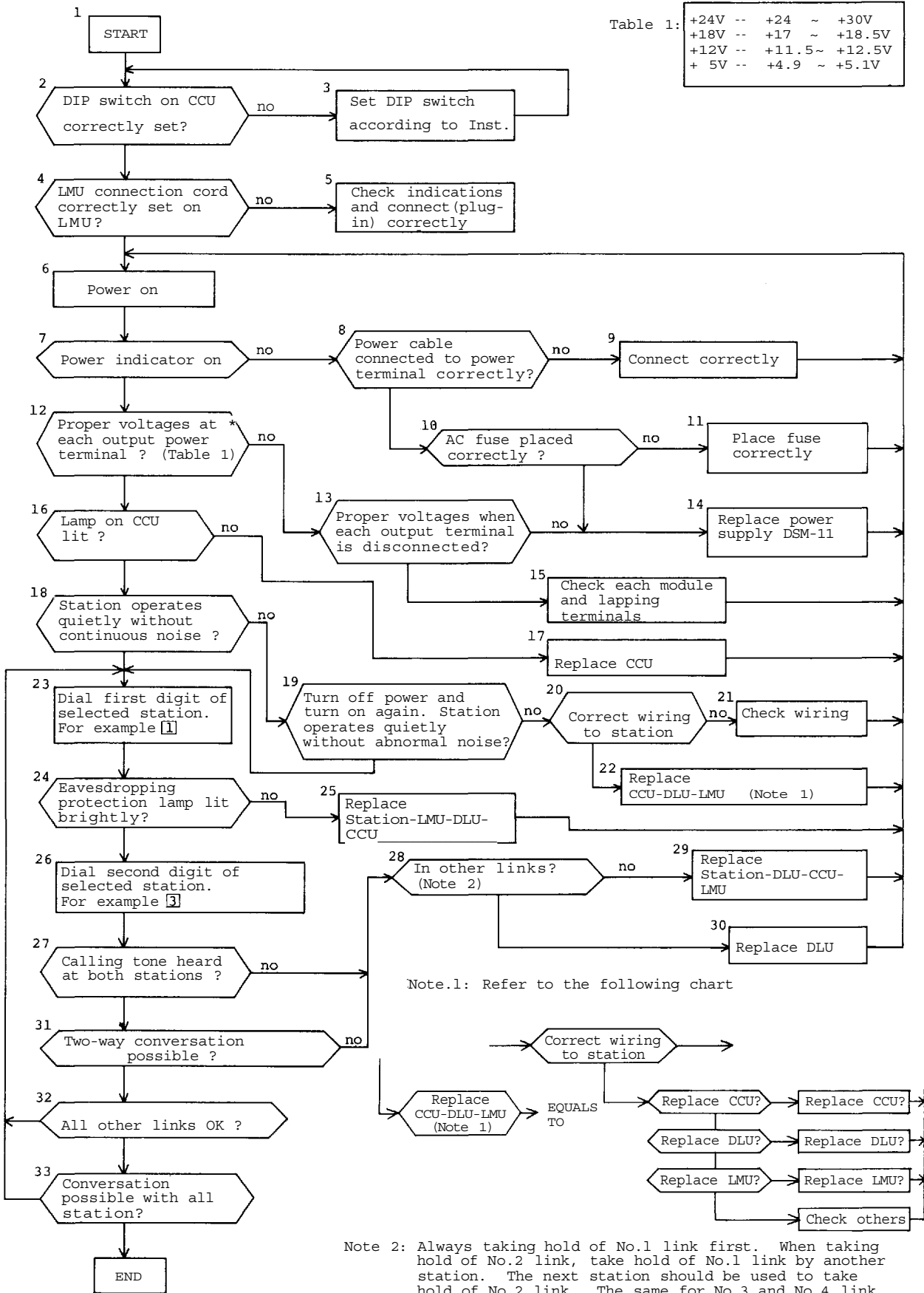

8-1. FAULT IN EXCHANGE

Before power supply (DSM-11) check, confirm the following three points to eliminate elementary faults:

1. Is voltage selector set correctly ?
2. Is AC power supplied ?
3. Is the connection made between DSM-11 and TBM-11?

Start checking after disconnecting all wiring connected to DC output of the power supply unit.

SYMPTON	CHECK-ITEM					
Exchange does not operate.	All DC output voltages are correct.	* Over-current flows into one of plug-in units.				
	All or one of DC output voltages are not correct.	* Fault in the power supply unit DSM-11.				
Abnormal voltage of +24V terminal.	Right range: +24 ~ +30V	* Replace AC fuse. * Incorrect setting of the voltage selector. * Faulty power transformer.				
Abnormal voltage of +18V.	Right range : +17.5 ~ +18.5V	* Faulty 2SA-671 (TV ₂). * Faulty NJM-305 (M ₃)				
Abnormal voltage of +5V or +12V.	Right range: +4.9 ~ +5. IV +11.5 ~ +12.5V	* Faulty 2SA-671 (Tr ₂). * Faulty NJM-305 (M ₃).				
Blown AC fuse.	All DC output voltages are correct.	* Over-current flows into one of plug-in units. * Replace fuse according to the following.				
		<table border="1"> <thead> <tr> <th>AC MAINS</th> <th>Fuse</th> </tr> </thead> <tbody> <tr> <td>AC: 110 ~ 120V</td> <td>3A</td> </tr> <tr> <td>AC: 220 ~ 240V</td> <td>1.5A</td> </tr> </tbody> </table>	AC MAINS	Fuse	AC: 110 ~ 120V	3A
AC MAINS	Fuse					
AC: 110 ~ 120V	3A					
AC: 220 ~ 240V	1.5A					

1. One of transmitting lines (T-Line) is disconnected.

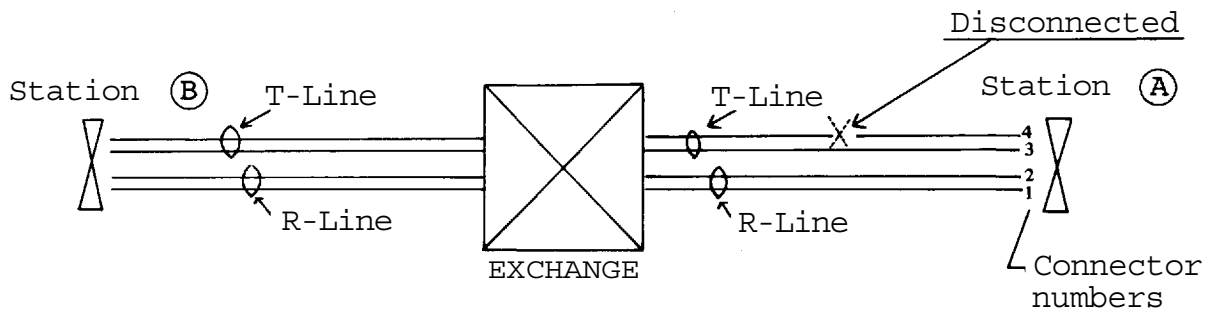

- Sympton:
- 1-1 A can make dialing.
 - 1-2 A can hear B .
 - 1-3 B can not hear A .
 - 1-4 Noise is heard at B .
 - 1-5 Noise increases at B when Press-To-Talk bar is pressed at A .

2. One of receiving lines (R-Line) is disconnected.

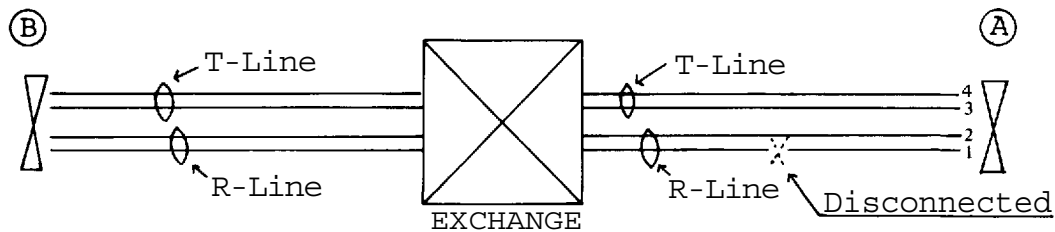

- Sympton:
- 2-1 A can make dialing without dialing tone.
 - 2-2 When B dials A , busy tone or dial tone will be heard at B immediately after the calling tone.

3. T-Line and R-Line are shorted or mixed up.

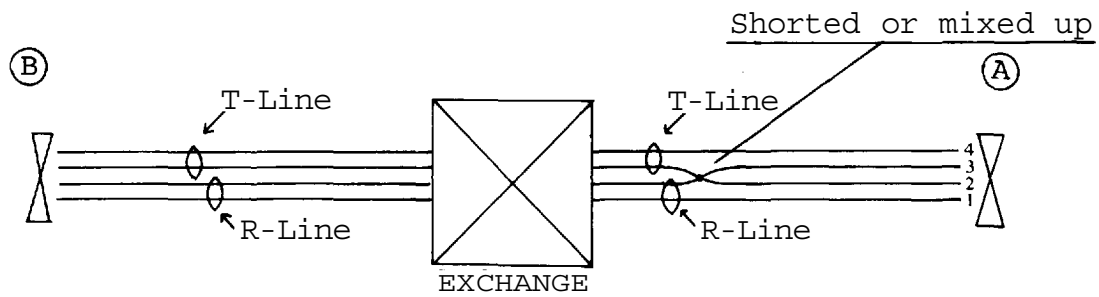

- Sympton: 3-1 A can not dial.
 3-2 Conversation is impossible between stations.
 3-3 When B dials A , noise will be heard at B immediately after the calling tone.

4. T-Line and R-Line are connected conversely.

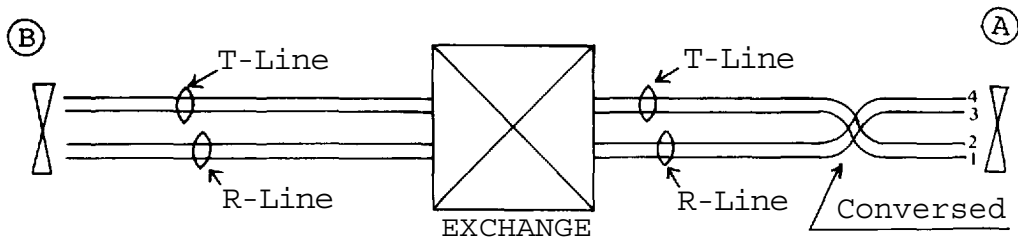

- Sympton : 4-1 A can not make dialing.
 4-2 Conversation is impossible between stations.
 4-3 When B dials A , noise will be heard at B .

8-2. FAULT IN SPECIFIC STATION ONLY

Find the cause according to the following table if the fault lies with a specific station only, not with all stations.

SYMPTON	CHECK-ITEM	CAUSE
Dialing can not be made at privacy off mode.	Replace the station and make sure that the station is not faulty.	<ul style="list-style-type: none"> * Disconnection of both T & R-Lines. * Guard resistor 330Ω on LMU is burned out due to T & R-Lines short. * T & R-Lines are shorted.
Specific key does not operate.	Replace the station and make sure that the station is not faulty.	<ul style="list-style-type: none"> * Fault in key board switch or matrix circuitry. * Fault in the dial generator. (Replace PCB board.)
Calling tone can not be heard. Sound from the other party can not be heard.	Same symptom remains even if the station is replaced.	<ul style="list-style-type: none"> * Short or open in R-Line. * Fault in the demodulation circuitry on LMU. (Check LM-380, MT-547.)
	Becomes normal if the station is replaced.	<ul style="list-style-type: none"> * Disconnection of R-Line or improper connection of the station connector. * Fault in MT-547 on LMU. * Station fault.
Sound is not transmitted to the other party.	Same symptom remains even the station is replaced.	<ul style="list-style-type: none"> * Short or open in T-Line. * Fault in the modulation circuitry on LMU.
	Becomes normal if the station is replaced.	<ul style="list-style-type: none"> * Fault in MIC circuitry of the station. (Replace MIC or PCB)
On dialing, noise is heard by the called party.	Same symptom remains even the station is replaced.	<ul style="list-style-type: none"> * One of T-Lines is disconnected. * Fault in LMU.
	Becomes normal if the station is replaced.	<ul style="list-style-type: none"> * Fault in MIC element. * Fault in T-Line of the station. * Low frequency oscillation of MIC AMP. (Faulty bypass capacitor)

<p>Sound of the other party is broken during call.</p>	<p>Same symptom remains even the station is replaced.</p>	<ul style="list-style-type: none"> * Adjust the volume control of station speaker if the room produces reverberation. (Lower the volume.) * Increase the gain of MIC AMP. * Replace PCB after checking if MIC unit is not touching its case.
<p>Immediately after the calling tone, the line switches to cancel, busy, dial tone, etc.</p>	<p>Same symptom remains even the station is replaced.</p>	<ul style="list-style-type: none"> * One of R-Lines is disconnected. * Fault in optically coupled isolator TLP-504 on LMU. * Fault in MT-547 on LMU or in the station.
	<p>Becomes normal if the station is replaced.</p>	<ul style="list-style-type: none"> * One of the R-Lines is disconnected or the station connector is not connected properly.

8-3. SPEECH AND FUNCTION TEST

1. Speech Test

After completing the wiring check and the power supply and exchange test according to the system flow chart, the speech test for each station can then take place.

- * Call every station one by one from any master station and examine the speech quality and sound volume.
- * The sound volume can be adjusted by the volume on the rear of the station. (Fully clockwise for maximum)
- * A call to a station in the room produces reverberation and may present broken sound. Turn down the volume of the station speaker until the sound becomes normal.
- * Each station must be located properly where no feedback will occur between station and external speakers. The gain adjustment of the paging amplifier is also important in order to avoid troublesome feedback.
- * The Press-To-Talk bar on the station keyboard must be used for the speech test when stations are installed in high noise areas (more than 60dB noise).
- * Speech quality (broken sound, natural conversation, tone quality, etc.) must be tested with each link. (Refer to the system check flow chart Note 2.)

2. Function Test

- * Check all employed functions with a few stations near the exchange.
- * Use all number keys including C and . , Press-To-Talk bar, Vol. L/H and privacy switch to test all functions.

EXAMPLE: + Both calling and conversation tests with station number 10 through 41.

+ Change the position of Vol. L/H and make sure that the switch works.

+ Turn the privacy switch ON. Is privacy tone heard from the station when someone calls ?



TOA ELECTRIC CO., LTD.
KOBE, JAPAN